



Ионекс

Тольятти: (8482) 25-82-40, (8482) 25-82-85, (927) 775-49-65, (906) 128-12-68, tlt@ionexedm.ru
Москва: (499) 782-61-17, (916) 627-56-24, (926) 300-12-42, msk@ionexedm.ru
Томск: (3822) 23-16-80, (909) 543-16-80, tomsk@ionexedm.ru

www.ionexedm.ru

Catalogue DE 3008

FIXTURING SYSTEM **4000** FOR WIRE EDM

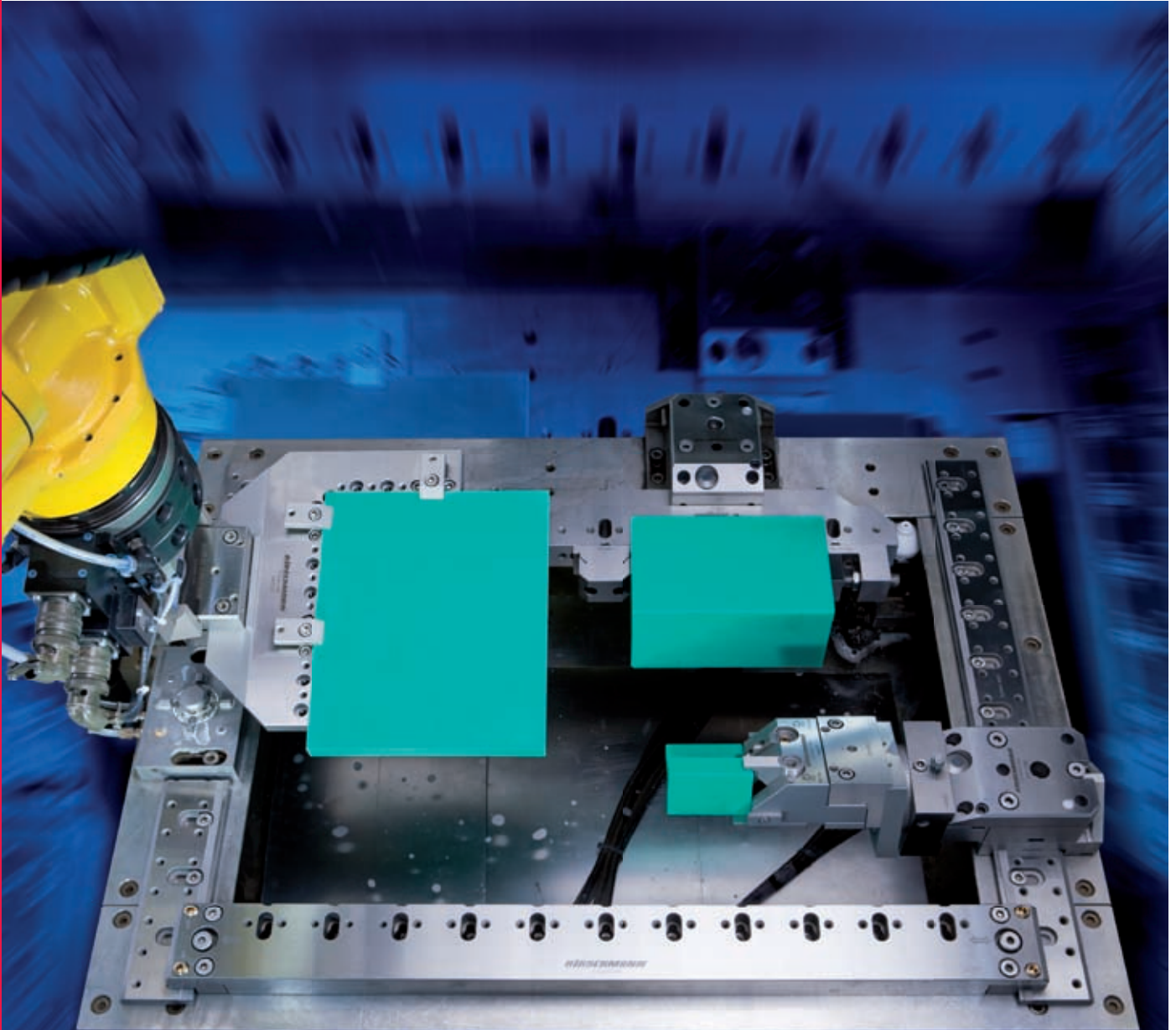

0.002 mm (0.00008") repetitive accuracy
integrated x-y-z references
solid, compact, economical

**Holds tightly,
changes quickly,
always wins.**

- High precision and versatility weights up to 150 kg (330 lbs)
- Solid referencing, not influenced by high flushing pressures
- Automation ready
- Minimal contact of the systems reference planes
- 0.002 mm (0.00008") repetitive accuracy (on-off, position to position)
- Rust-proof
- Not affected by dust
- Not affected by heat. The coordinate position is never lost, even in case of an extreme temperature rise (no flexing).
- Compatible to all Fixturing Systems by HIRSCHMANN
- Workpiece palletizing incorporating automatic or manual change
- High repetitive accuracy from set-up to machine
- Simple and precise workpiece handling

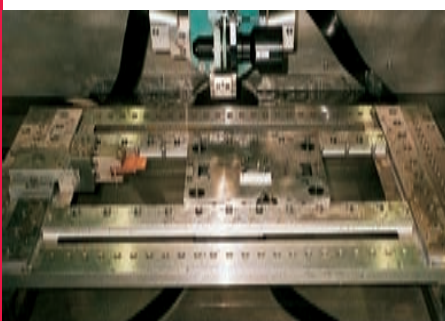
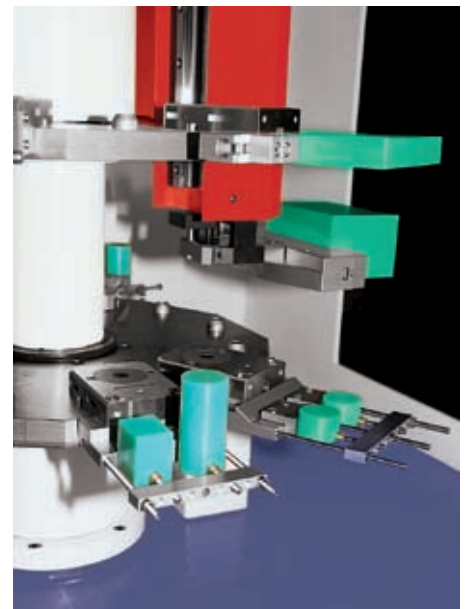
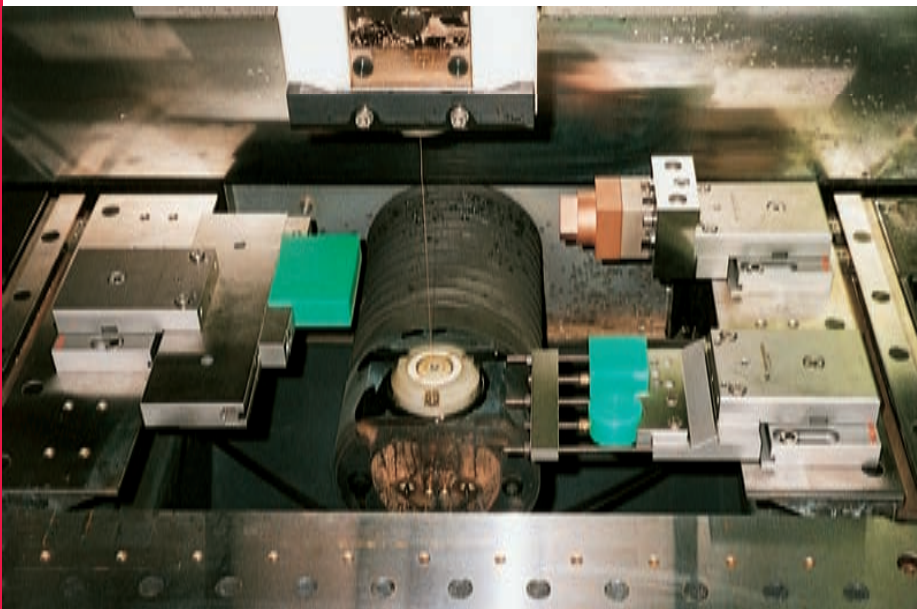
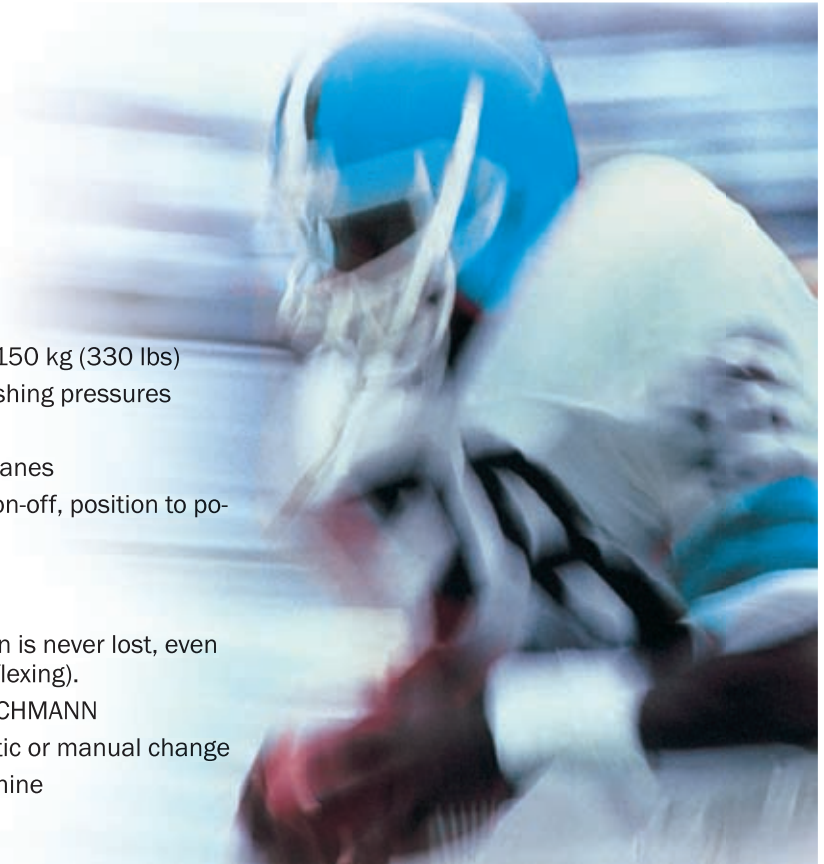

Fixturing System 4000

Operation

Most tools are supplied together with an operating manual. Correct operation cannot be ensured and danger to personnel and machine cannot be excluded unless these operating instructions or information given in this catalogue are observed.

Precision

The individual tool planes incorporate hardened and precision ground X and Y centering prisms and separate Z-supports. This assures position centering of each tool with a repetitive accuracy (consistency) of < 0.002 mm (0.00008").

Service and Maintenance

Since the Fixturing System is subject to chemical and physical influences, maintenance and service has to be performed with special care.

The current flow requires a good connection (contact) between beams and workpiece holders. The conductivity of the water along with chlorides normally contained in water, can influence the rust-resisting property of the Fixturing Systems.

Residues from electrical discharge process especially copper particles which can develop secondary EDMing (corrosion), must be removed once a day. Never use abrasive products. Only use a clean and soft cloth. For maintenance we recommend CONTROXID (page 25) or NERV-DUL (available in US market).

Technical Modifications

All products shown in this catalogue are subject to ongoing improvements and developments; we reserve the right to make modifications without notice.

Quality according to EN 9100

All products of HIRSCHMANN GmbH are manufactured using the latest production methods. All products are submitted for EN 9100 (air and space industry standard) quality assurance.

Warranty

We provide a 12 months warranty for all Fixturing System parts starting from the invoice date, and assuming correct use and maintenance as specified has been observed. The warranty is restricted to replacement or repair, free of charge, of any defective parts. Claims arising from improper use or handling shall not be considered. Warranty claims shall be submitted without delay and in writing.

CONTENTS

■ Fixturing System 4000 In Use	2
■ Accuracy, Quality, Cleaning, Warranty	3
■ Introduction	4
■ Selection of Clamping Devices	5
■ Fixturing Systems in General	6 – 7
■ Presetting, Change of Workpiece	8
■ View to Amortization	9
■ Basic Set 4000	10
■ Beams	11
■ Insulating Set, Support Holders, Countersupport	12
■ Clamping Jaw Set	13
■ Presetting Stations	14 – 15
■ Clamper	16
■ Pallets	17
■ Vises, Spacers	18 – 19
■ Prism Vises and Holders	20 – 21
■ Vertical Chuck Jaws, Clamping Inserts	22 – 23
■ Uniholder	24
■ Miniholder, Adhesive, Anticorrosive	25
■ Mini-Holder, Clamping Angle, Magnet-Holder	26
■ Basic-Holder, Beam Vice Kit, Clamping Beam	27
■ Pallet Clamper and Adapter Peg Rotating Unit, Vertical Unit	28
■ Reference Pallet, Shank Clamping Chuck	29
■ Customized Holders	30 – 31
■ Rotating Spindles and Speed Control Units	32
■ Adjustable Clamping Element	33
■ Rotary Tables and A-Axes	34
■ Automation	35



HIRSCHMANN GmbH

Introduction

Fixturing system 4000 for wire EDM

To compete in a global market, every effort must be made to utilize the full potential of today's "State of the Art" production systems. When manually clamping workpieces in the machine tool without the use of a quick changing system, valuable machine uptime is wasted eroding profitability. Pre-setting the workpieces outside the machine tool allows fast load & unload times allowing maximum productivity in the machine tool.

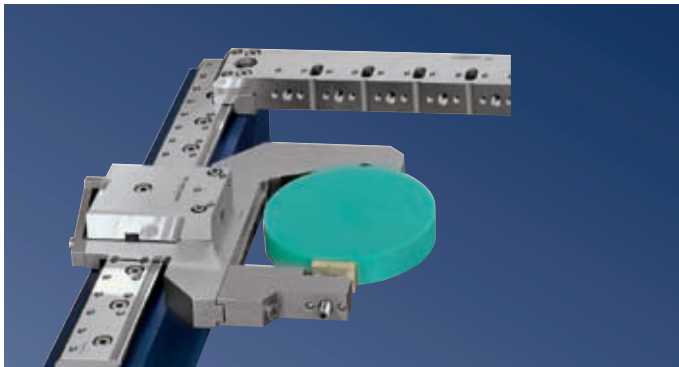

HIRSCHMANN provides perfected well engineered, solutions with intelligent modular **Fixturing Systems, presetting stations and automated robotic loading devices**, reducing set-up, measuring and presetting on the machine to a minimum and reaching maximal efficiency of the machine.

In a modern fabrication machine down-times, for example while setting-up the machine tool, unnecessarily block production time and must be reduced to a minimum.

Advantages of HIRSCHMANN Fixturing System 4000

- Optimized of productivity through better utilization of the machine
- Higher profits due to decreased down time
- Flexibility for production or job shop applications
- Set-up and presetting of workpieces outside the machine tool
- Reliable accuracy from presetting to the machine tool, no re-adjustment necessary
- Justifiable cost that are easily amortized

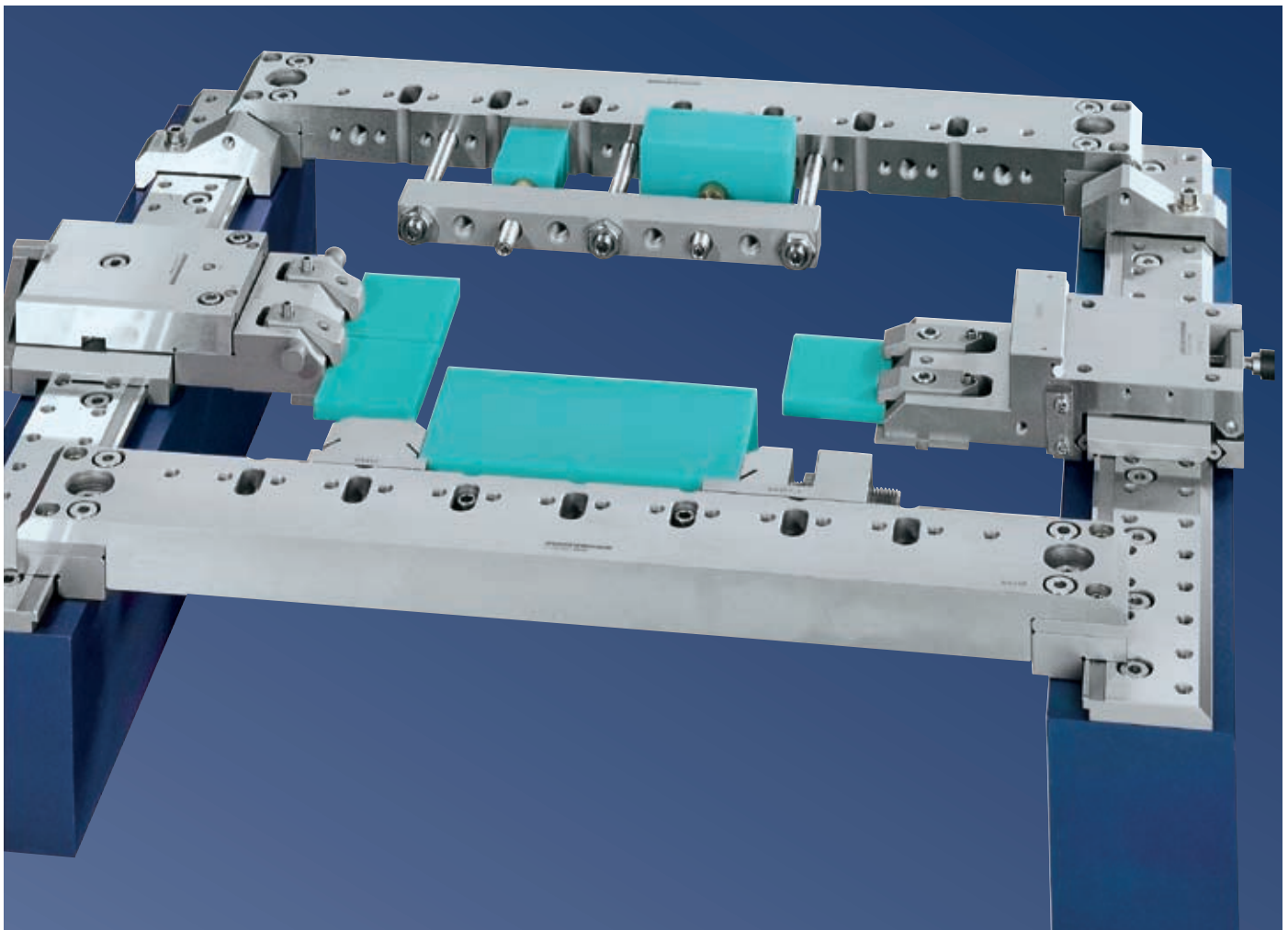

Selection for the right tools

To select correct components of the clamping system it is necessary to take an inventory of the machine types and models in use. These data in conjunction with the shape, dimensions and weight of the workpieces allow a proper selection to be made. In addition, requirements for present or future automatic loading of workpieces should be considered.

For workpieces with a weight up to 30 kg (66.15 lbs) and dimensions up to 200 x 180 mm (7.880 x 7.090) it is recommended to use pallet system including holders shown in this catalogue. Special holders (pages 30 & 31) can also be designed upon request to offer additional flexibility for clamping workpieces.

For larger workpieces of various dimensions and weights up to 150 kg (330 lbs) the HIRSCHMANN frame concept is recommended. It can also be used with the pallet system to hold smaller workpieces.

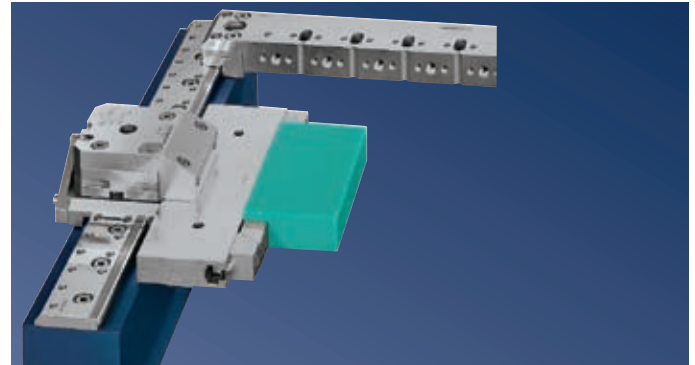

Starting with a Basic Set 4000 plus (partial or full frame system), is an economical way to fixture the machine tool. Additional components of the 4000 system (additional Basic Set or pallet holders), can be applied based on day to day needs.

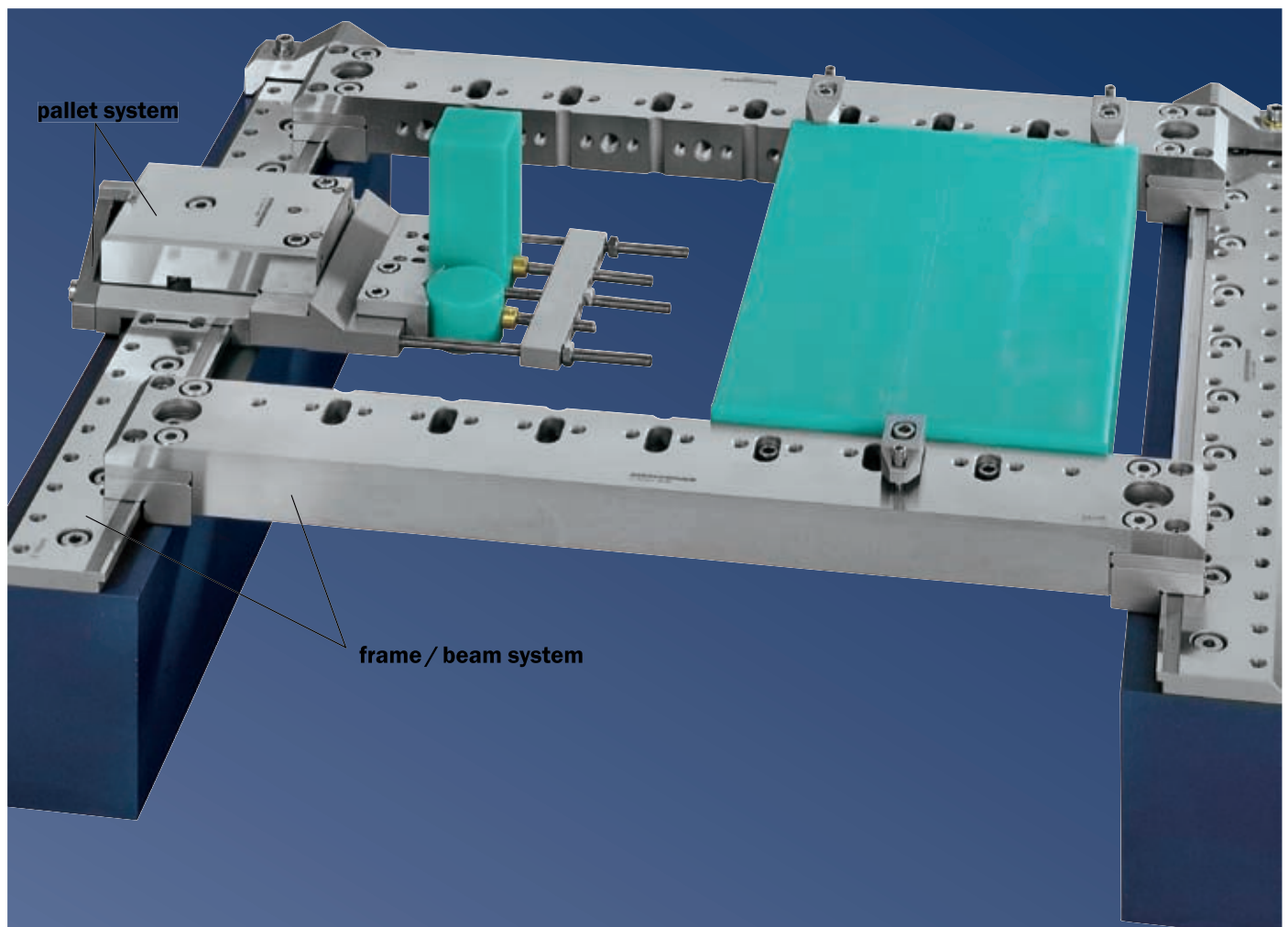

Fixturing Systems in General

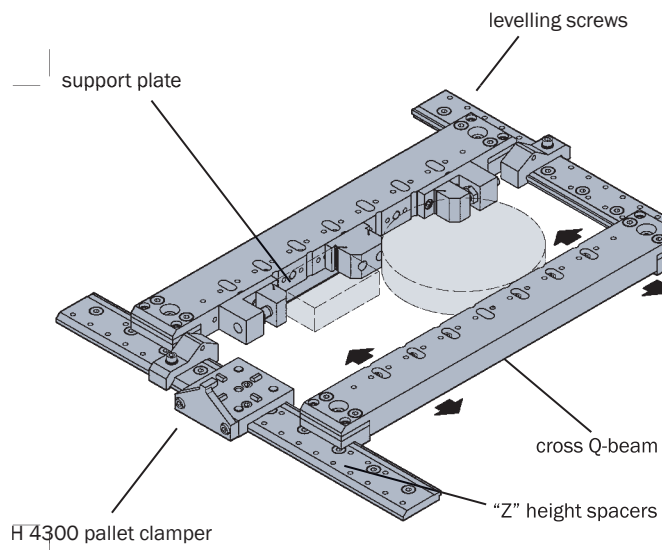

Basic Set / Beam System 4000

For universal and quick clamping of workpieces up to 150 kg (330 lbs).

Workpieces can be clamped crash-free inside machine's cutting area, between or on the adjustable cross Q-beams. Supporting plates can be mounted simple and quickly at the cross Q-beams to help position and support large and heavy workpieces on the Z-zero surface. Workpieces can be adjusted for flatness using the levelling screws integrated in the cross Q-beams.

To avoid collision of the lower wire guide with supporting plate, the cross Q-beam can be mounted in two heights by either inserting or removing the "Z" height spacers. This allows positioning the workpiece at Z-zero or 6 mm (0.240) above. Small workpieces can also be clamped directly at the cross Q-beams by using other devices shown in this catalogue.

The clasper H 4300 can be mounted on basic B-beam in 25 mm (0.980) increments to quickly clamp pallets and holders of the 4000 system.

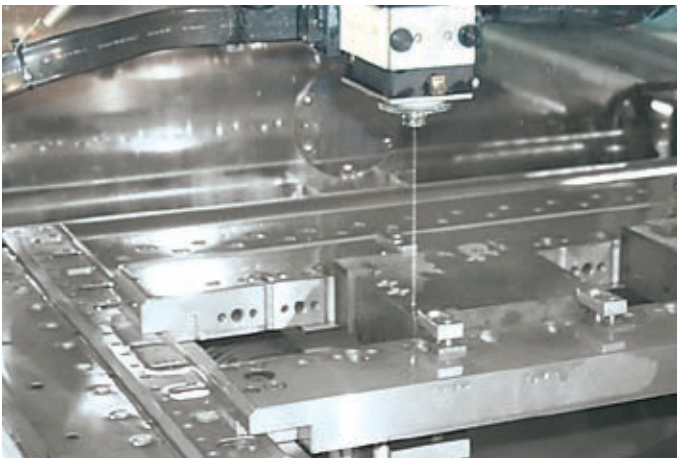

Characteristics:

- Workpieces weighing up to more than 150 kg (330 lbs)
- Constant accuracy
- Rust-proof
- Universal, crash-free clamping of work pieces
- Reduction of set-up time
- Set-up possible in and outside the machine
- Suitable for all Wire EDM

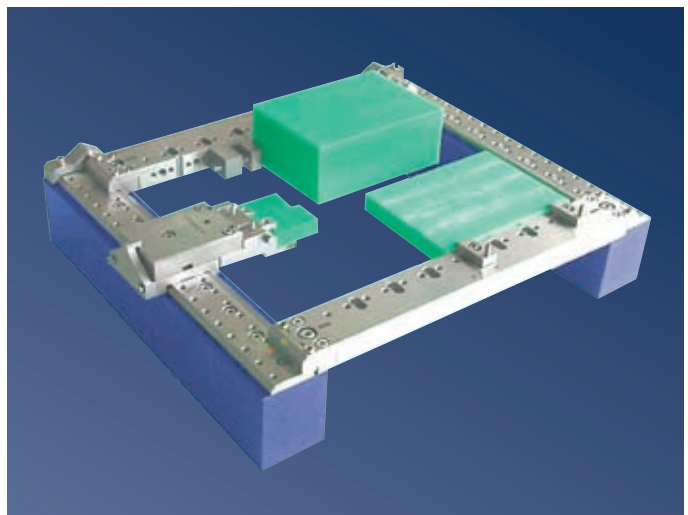
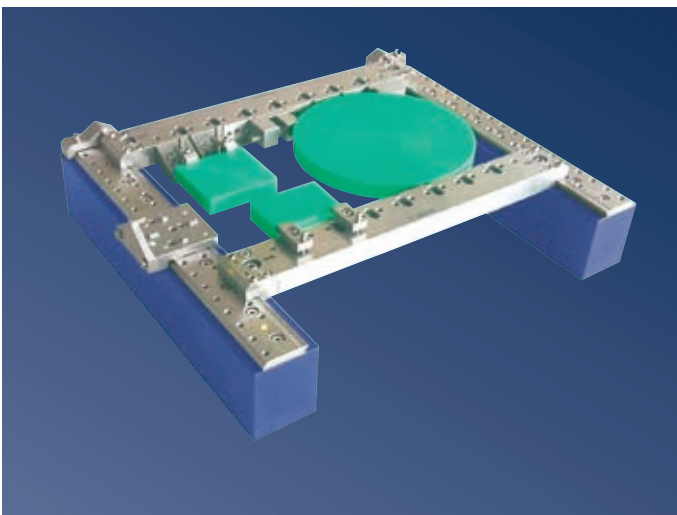

The Optimum – Pallets with Universal Holders

Can be used in combination with a Basic Set or as a palletized solution for single or multiple parts of small or medium-size.

First, the universal holder of choice is fastened securely to a pallet. The pallet with the holder is then mounted and secured (via manual turning a single screw or by pneumatics) to a clammer which is permanently mounted to a pre-setting station.

The workpieces are clamped in universal holders and are precisely adjusted on the station. The pallet, holder and workpiece are then transported via hand or with robotic device EROBOT, to a clammer at the machine tool table.

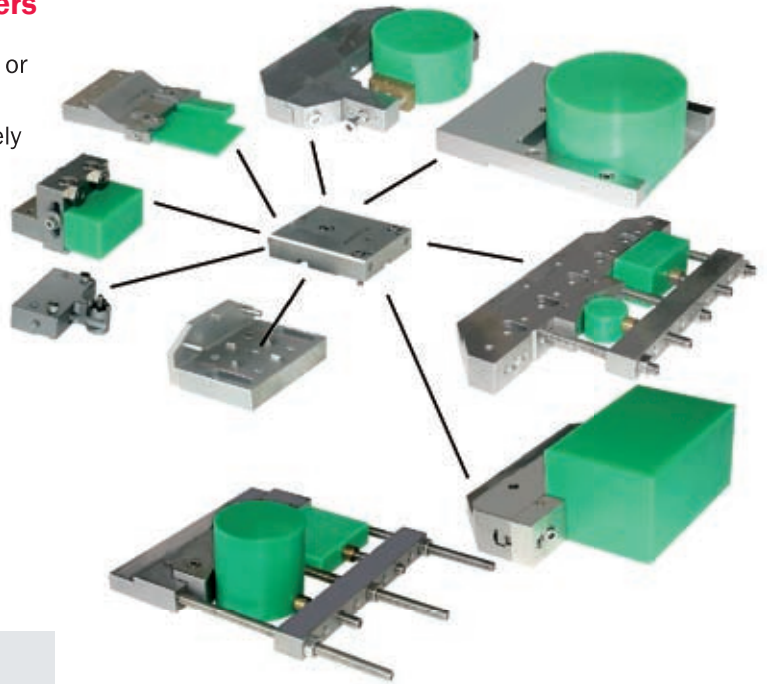

Characteristics:

- 0.002 mm (0.00008) repetitive accuracy
- Crash-free clamping of workpieces weighing up to 30 kg (66.15 lbs)
- Secure and precise set-ups on external presetting station
- Manual and automatic pallet change
- Rust-proof
- Compatible to all HIRSCHMANN Fixturing Systems

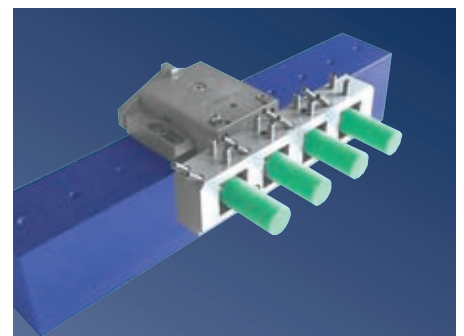
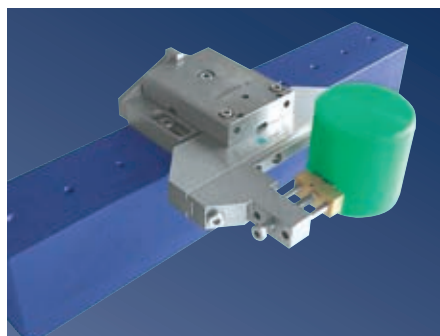
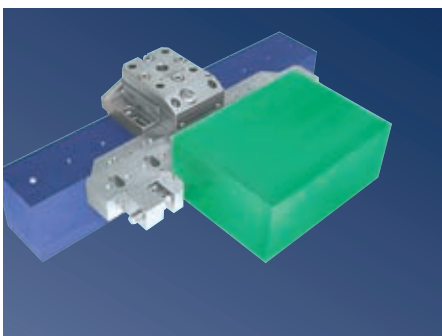
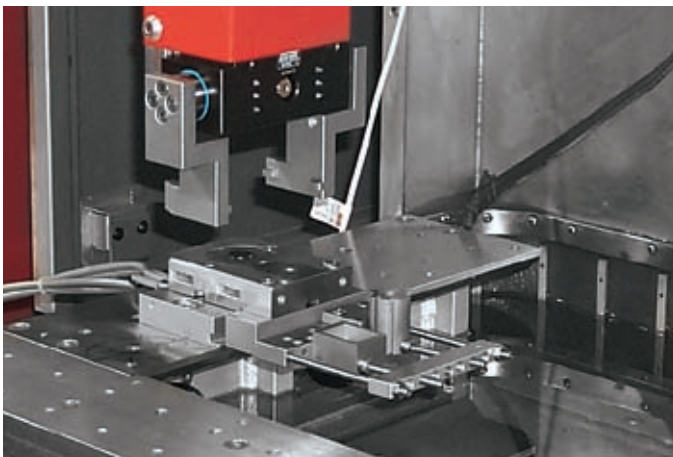

Presetting while machine is working

Minimum machine down time is a result of rapid workpiece change within a few seconds



1. Clamp the workpiece in the holder



1. Put pallet into the clamber



2. Accurately adjust the workpiece

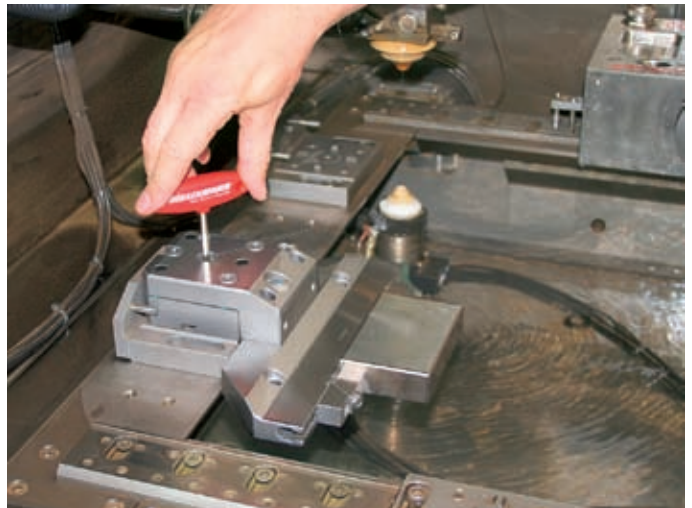

2. Clamp the pallet



3. Withdraw presetted workpiece



3. Erode the workpiece

View to amortisation

... or how fast can a Fixturing System save the money.

Compare set-up times:

Resetting **without** using the HIRSCHMANN Fixturing System

1. Remove machined workpiece
2. Clean machine table
3. Put in new workpiece
4. Look for suitable clamping materials
5. Clamp the workpiece with toe clamps to the machine table
6. Adjust workpiece with the help of the machine functions (takes most of the time)
7. Start the program

START after about 25 – 30 minutes

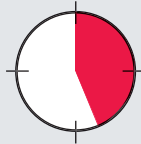

Resetting **with** the HIRSCHMANN Fixturing System

1. Release chuck, withdraw holder and workpiece
2. Put in and clamp the new workpiece that has been pre-setted outside the machine
3. Start the program

START after about 3 minutes



Potential to save

Having 4 workpiece changes a day, you can save set-up time of about 100 min./day using HIRSCHMANN Fixturing System.

Time of amortisation (example for calculation)

Machine hour rate 50,- (USD, GBP, EUR)

Saved set-up time per day = 100 minutes means approx. 83,- (USD, GBP, EUR)/day

Invested money for Fixturing System 13.000,- (USD, GBP, EUR)

Time of amortisation $13.000,- (USD, GBP, EUR) / 83,- (USD, GBP, EUR) = 156,6 \text{ days} \sim 3/4 \text{ year}$

Reduction of machine-down time

Estimated workdays per year = 220 days
 Estimated machine-down time per day = 100 minutes

Result in one year: 220 days x 100 minutes = 22.000 minutes ~ 366 hours more machine operating time!

Potential to save in a year $366 \text{ hours} \times 50,- (USD, GBP, EUR) = 18.300,- (USD, GBP, EUR)/\text{year}$

Potential to save can be increased even more, if more than 4 work piece changes a day take place or if there is more than one EDM in use.

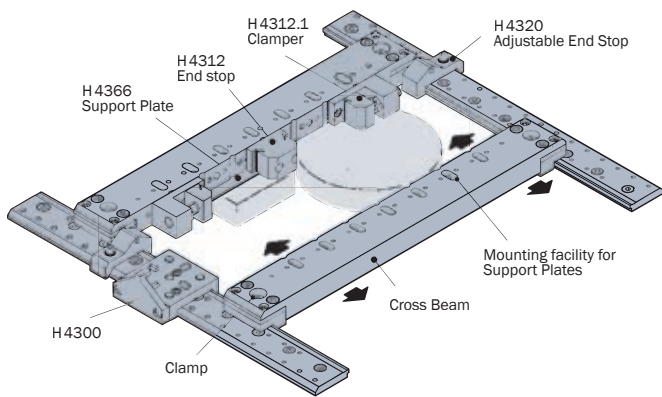

The Basic Set

The HIRSCHMANN Basic Set is an ideal equipment for the wire EDM. It is assembled from the beams shown on page 11, and matched to the individual machine model in question.

Almost all workpieces can be clamped inside the cutting area and fixed with a repeatability of < 0.005 mm (0.0002") between the cross beams, which can be inserted from above or from the front. They are infinitely adjustable and quickly locked in any position, using only a few additional clamping elements.

Large workpieces can be clamped directly between cross beams. Support plates are included to help secure or hold the workpiece at the Z-zero level during clamping. Levelling of the workpiece can be done with the built in elements within the cross beam.

To avoid collision of the lower wire guide with the supporting plate, the cross Q-beams can be mounted in two heights by either inserting or removing the "Z" height spacers. This allows positioning the workpiece at Z-zero or 6 mm (0.24") above.

Smaller workpieces are clamped in workpiece holders. The clamper H 4300 can be mounted on basic B-beam in 25 mm (0.98") increments to quickly clamp pallets and holders of the 4000 system.

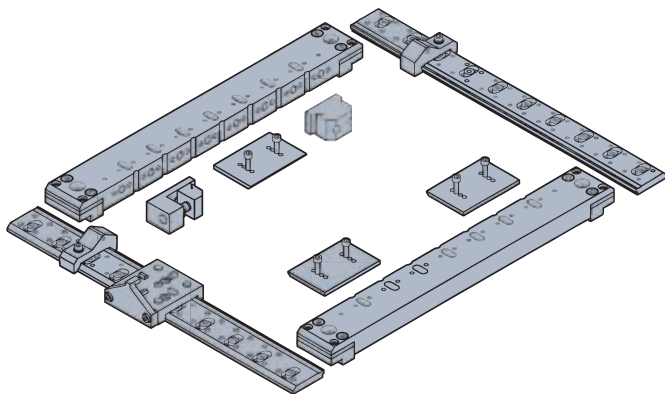

Basic Set 4000 plus

The HIRSCHMANN Basic Set plus is the ideal equipment for Wire EDM machine. Expanding the set is possible at any time.

Contents:

- 2 Basic B-beams with fastening screws
- 2 Cross Q-beams Q 42..
- 2 Adjustable End Stops H 4320
- 3 Support Plates H 4366
- 1 Beam Vise Kit consisting of: 1 End stop H 4312 and 1 Clamper H 4312.1
- 1 M-Clamper H 4300

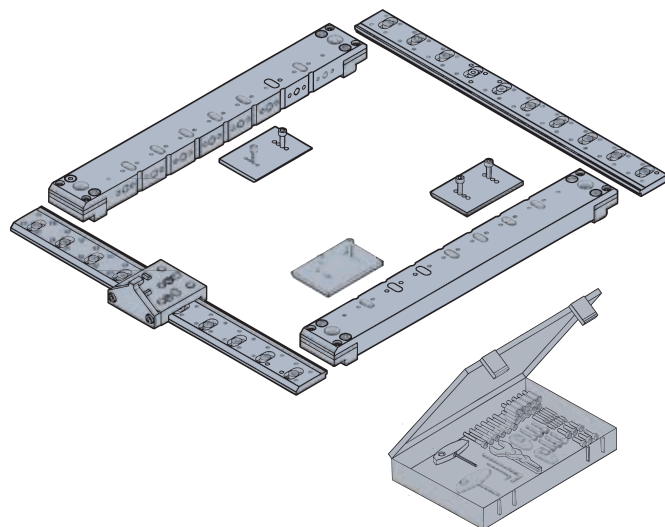

Basic Set 4000

The Basic Set is the economy-priced version of the Basic Set 4000 plus. Expanding the set is possible at any time.

Contents:

- 2 Basic B-beams B 40.. series with fastening screws
- 2 Cross Q-beams Q 42.. series
- 3 Support Plates H 4366
- 1 M-Clamper H 4300
- 1 Clamping Jaw Set H 2850

B 40.. Basic Beam

Hardened basic beams, fastened to the machine's base with screws, are used to guide and position the cross Q-beams. The Solid Jaws H 4320 positioned in steps of 25 mm (0.980) to serve as a reference stop for the Q-beams and the Clamper H 4300 and Adapter H 4380. The beams are available with steps of 50 mm (1.970). Length and hole pattern of the fastening screws are matched to the machine model in question.

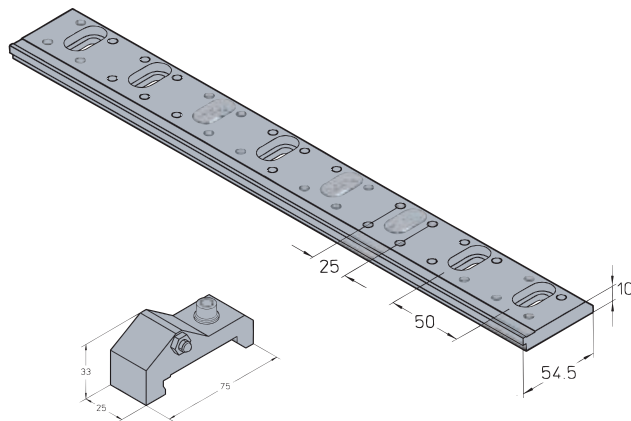

H 4320 Adjustable End Stop

Adjustable end stop is used on basic beams for repetitive positioning of cross beams. Positioning and repetitive accuracy < 0.002 mm (0.00008"). The Basic Set 4000 plus contains two end stops.

Q 42.. Cross Beam

The movable cross Q-beam can be clamped in any position between two basic B-beams. The cross Q-beam can be inserted between the basic beam from the top or from the side. Workpieces mounted directly on the Q-beams, can be adjusted by means of two adjustment screws, which are next to the tightening screw of the beam. Larger workpieces weighing up to 150 kg (330.75 lbs) can be clamped between the cross Q-beams with the assistance of the Support Plates H 4366. To avoid collision of the lower wire guide with the supporting plate, the cross Q-beam can be mounted in two heights by either inserting or removing the "Z" height spacers. This allows positioning the workpiece at Z-zero or 6 mm (0.24") above. Cross beams having a length of more than 600 mm (240) are delivered with a larger cross-section (36 x 85 mm) (1.41" x 3.34") instead of 30 x 60 mm (1.18" x 2.36"), to avoid sagging of the beam because of the large length.

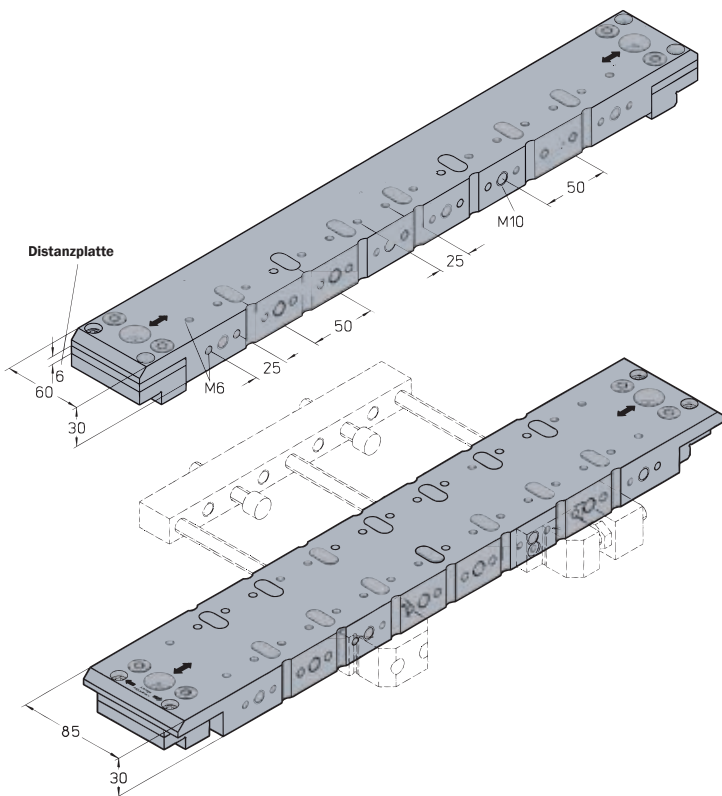

QD 42.. Cross Beam

This cross QD-beam can be equipped on both sides with clamping elements and is often used as third beam between standard cross beams.

Q 42 KLI Insulating and Clamping Element (2 pcs.)

The cross beams can be insulated by exchanging the clamping elements for these insulating elements, which is needed in machines requiring insulated workpieces for fine finishing. Further insulation possibilities are shown on the pages 12 and 17.

H 4366 Support Plate

Support plates are attached to the cross beams and used for clamping or supporting larger workpieces between two cross Q-beams. The support surface is variable between 4 mm (0.16") and 25 mm (0.98"). Workpieces are clamped by clamping jaws of the Clamping Jaw Set H 2850, page 13. Maximum load 50 kg (110.23 lbs).

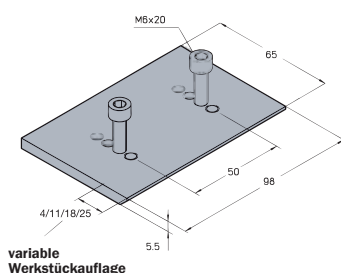

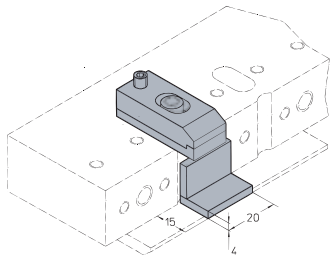

H4255 Insulating set (3 pcs.)

Each consisting of two ceramic insulating plates, that can be put between a workpiece and the cross Q-beam and support plate H4366, and one insulated clamping jaw.

Current must be directly supplied to the workpiece.

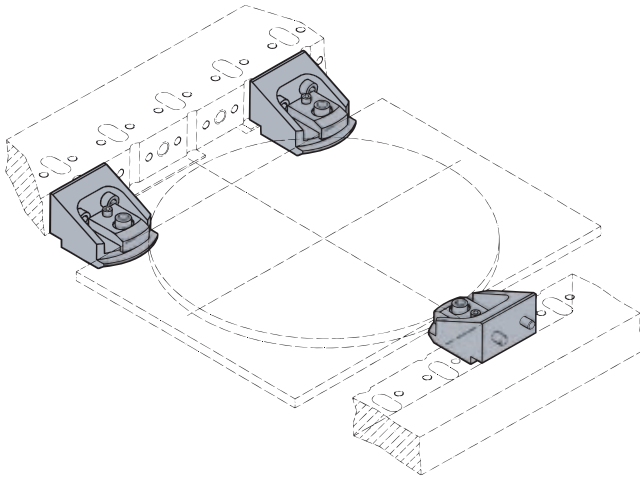

H4315 Supporting holder (3 pcs.)

Supporting holders can be mounted to the cross Q-beams to hold especially thin round and rectangular workpieces.

For heavy workpieces it is useful to support the holders with support plates H4366.

Clamping range can variously be increased by changing the clamping screws (contained in Clamping Jaw Set H2850).

Work pieces are adjusted with the levelling adjusting device of cross beams.

Maximum load 30 kg (66.15 lbs).

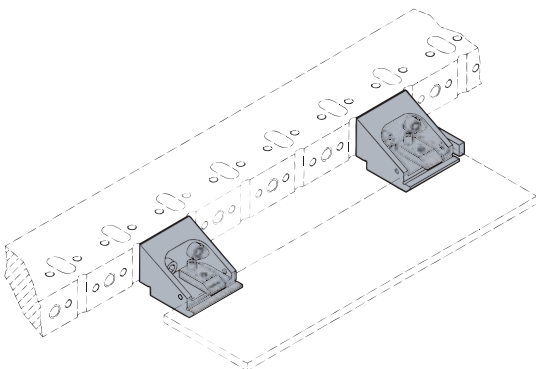

H4315.1 Support plat (2 pcs.)

Similaire au H4315 mais avec une face droite adaptée au serrage de pièce prismatique jusqu'à 10 mm d'épaisseur.

Butée latérale incluse.

Pour le maintien de pièce lourde il peut être nécessaire de renforcer les supports plats par une plaque d'appui H4366.

Les pièces peuvent être dégauchies grâce aux vis de réglage des traverses.

Charge maximale 30kg (66.15 lbs).

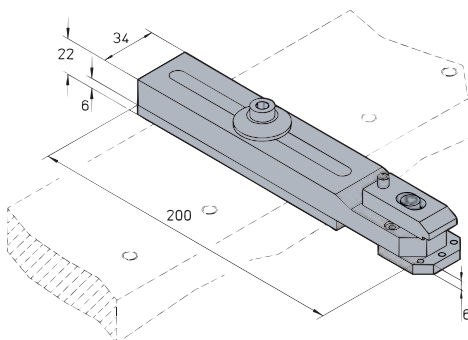

H4265 Contre-support

Pour supporter la face opposée des pièces bridées en porte à faux dans les courses de la machine.

Le contre-support est monté directement sur la table de la machine.

La pièce peut être positionnée au niveau 0 de la machine ou à plus 6 mm avec l'entretoise. Elle peut-être ajustée à l'aide des vis de réglage situées sur le contre support.

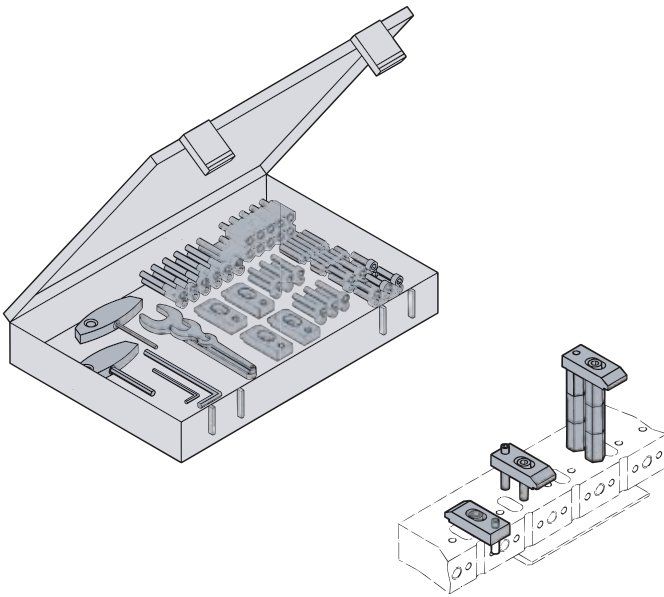

H2850 Clamping Jaw Set

The clamping Jaw Set consists of clamping jaws, support, bolts M6 length 20 – 40 mm (0.787" – 1.575"), setscrews M6 and also open-end M6 and internal-hexagon wrenches.

This clamping set is required when larger workpieces are placed between cross beams on the Support Plates H 4366 and clamped there.

Delivered in plastic box.

H2851 Clamping Jaw Set

Similar to H 2850 but M8.



H50 K Single-package System

For the attachment of workpieces to the Support Plates H 4232.1. SICOMET 85 is suitable because of its short setting time (90 – 150 sec.) and high tensile shear strength (~ 27 N/mm²).

The surfaces to be glued must be absolutely free of grease. Use at room temperature.

Storage at +20° C approx. 6 months, at -20° C approx. 12 months.

Delivery: Work bottle – contents 50 gr.

Presetting Stations – indispensable for efficiency in production

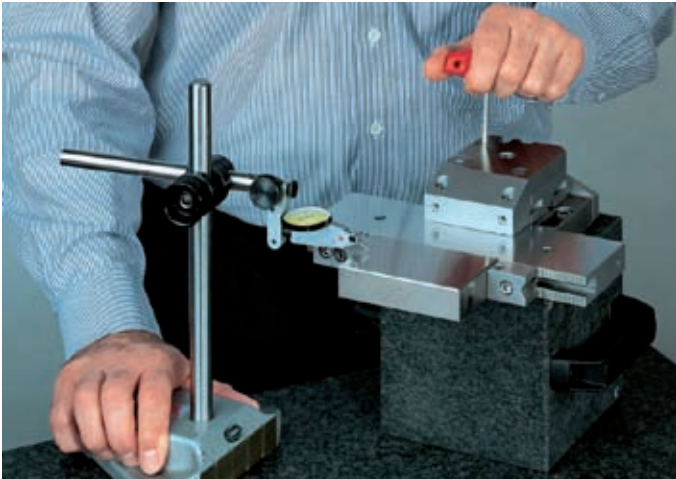

Measuring column requires:

- strong basement for high stability
- easy sliding free of vibrations
- front surface ground for part alignment and referencing

Please ask us for choose the right measuring column!



The investment costs of a Wire EDM are usually justified with a projected high degree of utilization. The ROI (return on investment) described on page 9 “View to Amortization”, shows how 400 more operating hours can be gained in a year. In order to achieve this ROI, presetting of the workpieces in a presetting station must be first implemented.

Set-up and presetting of workpieces outside the machine releases Wire EDM of unproductive set-up times and significantly reduces machine down time.

Presetting stations can be delivered as moveable or stationary unit or as separate components for individual mounting on a measuring plate.

Presetting can increase the productivity of new or existing machines already in use.

3-D Pallets H 4110 M and H 4110 P

For adjustment in X, Y and Z planes.

The 3D-Pallet adjustment is simple and easy to use. No further tightening is necessary after the adjustments are made in each axis.

Characteristics:

- For holders and workpieces weighing up to 30 kg (66.15 lbs)
- Wide range of adjustment (0.5 mm / 0.0197" on a length of 80 mm / 3.152")
- Quick and secure adjustment in X-, Y- and Z-direction
- Vibration free even under high flushing pressure
- Z-surfaces for Z = zero position are insulated against dust
- Quick and easy zero positioning
- 0.002 mm (0.0008") repetitive accuracy (on-off, position to position)
- Low profil construction allows optimal clearance with upper wire guide
- Cross-hair prism centering not effected by heat
- Rear surface ground parallel to prism for adjusting 3rd axis

Reference beam Reference disc Clamper



H4900 Presetting Work Station

The presetting work station is delivered complete in a sturdy stainless steel trolley and a granite surface plate 500 x 500 mm (19.7" x 19.7") of accuracy class 00.

A Clamper H 4000 is mounted on the granite plate on a riser. A small reference column (same height as the riser) used to support the workpieces while presetting them is also included.

The opposite guide beam, aligned parallel to the clamper, serves as a reference wall for the surface gauge.

Dimensions (B x T x H) approx. 680 x 580 x 1100 mm
 (26.972" x 22.852" x 43.34")

H4900.1 Presetting Work Station

Similar to H4900, but without the guide beam.

3rd axis is adjusted by positioning the pallet to the rear.

H4901 Presetting Work Station

Similar to H4900, but without trolley.

Dimensions (B x T x H) approx. 500 x 500 x 200 mm
 (19.7" x 19.7" x 7.88")

H4901.1 Presetting Work Station

Similar to H4901, but without the guide beam.

3rd axis is adjusted by positioning the pallet to the rear.

H 4905 Presetting Cube

Granite presetting cube is used on a larger granite plate together with the reference column. Includes the H4000 clamper and the reference column.

It can be placed on two sides ground to the H4000, and is suitable for presetting small workpieces.

Dimensions (B x T x H) approx. 150 x 150 x 200 mm
 (5.91" x 5.91" x 7.88")

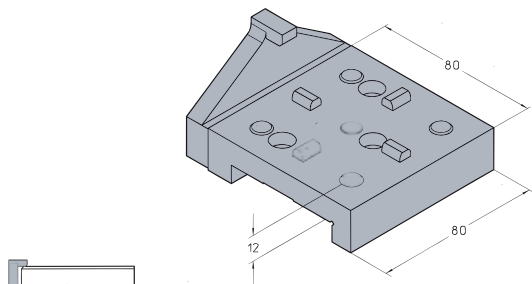

Latch for securing the pallet with workpiece in unclamped position

H4300 B-Beam Clamper (manual)

Manual clamper for the precise clamping of the M-Pallets H 4005, H 4105, H 4110P, through X & Y centering prisms and separate Z-supports. Central clamping with bolt M8. The manual clamper is provided with a securing latch for collision-free positioning of the pallets with aligned workpieces.

This clamper or also several clampers are screwed with three screws on the B-beam, at any position in steps of 25 mm (11").

Permissible workpiece weight, incl. workpiece holder 35 kg (77.17 lbs)
Positioning and repetitive accuracy < 0.002 mm (0.00008")

The Basic Set contains one Clamper H 4300.

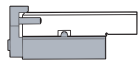
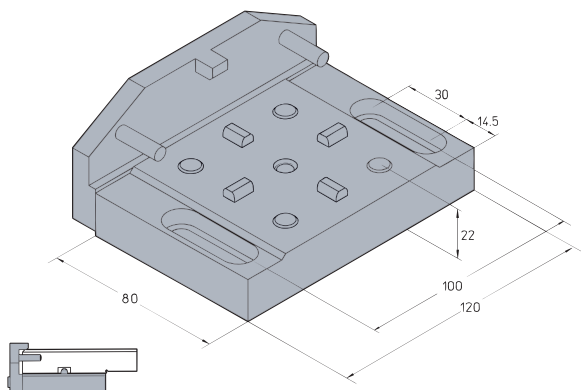

H4000 M-Clamper (manual)

Manual clamper with the same features as the H 4300, but mounts to the machine table. Front surface is ground for axis alignment.

The securing latch is equipped with two positioning pins which make the manual positioning of the pallets easier.

Permissible workpiece weight incl. workpiece holder 35 kg (77.17 lbs)
Positioning and repetitive accuracy < 0.002 mm (0.00008")

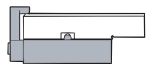
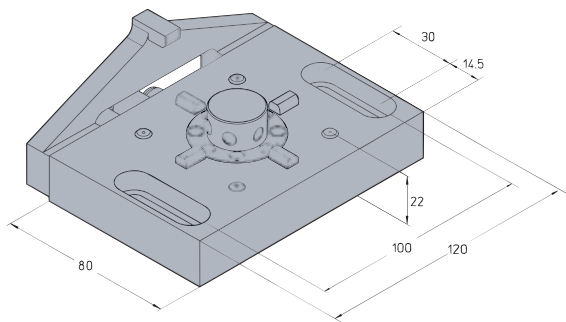

Remove securing latch for automatic use.

H4100 P-Clamper (pneumatic)

Pneumatic clamper with central power clamping for the automatic or manual positioning of the H 4105 Pallets and H 4110P 3D-Pallets. The pneumatic clamper is provided with a securing latch for collision-free positioning of the pallets with aligned workpieces during manual operation.

This clamper is also used for automatic workpiece change with EROBOT Workpiece Changer or other robotic devices.

Permissible workpiece weight incl. workpiece holder 35 kg (77.17 lbs)
Positioning/ repetitive accuracy < 0.002 mm (0.00008")
Compressed air min. 6 bars

3 m (3.28 yd) plastic hose, Ø 6 mm (0.24") are included in delivery.

H4100A Covering for P-Clamper

Covers the P-clamper against dirt during operation inside EDM.

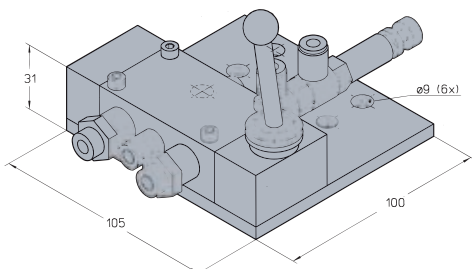

H4101 Pneumatic Control Unit

Manual control unit (valve) to activate functions (opening, clamping, cleaning) of Pneumatic clamper H 4100.

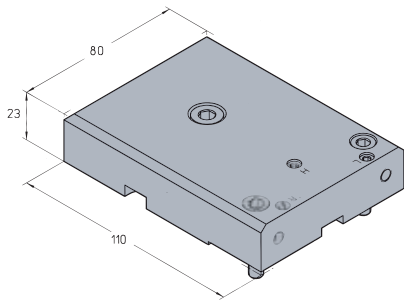

H4005 M-Pallet

For manual changing of workpieces. Fits only to B-Beam Clamper H 4300 and M-Clamper H 4000. Two axis levelling is standard.

All workpiece holders of System 4000 can be mounted to the pallet.

Max. workpiece weight, workpiece holder included 30 kg (66.15 lbs)

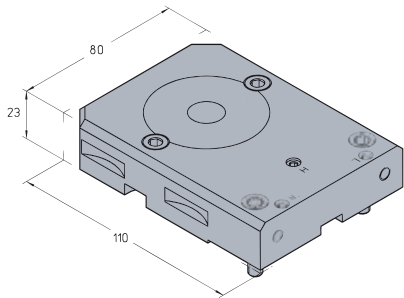

H4105 P-Pallet

For automatic and manual changing of workpieces. Fits to P-Clamper but also to B-Beam Clamper and M-Clamper. Two axis levelling is standard.

Mounting of holders similar to H 4005.

Max. workpiece weight, workpiece holder included 30 kg (66.15 lbs)
Pallet weight 1.5 kg (3.30 lbs)

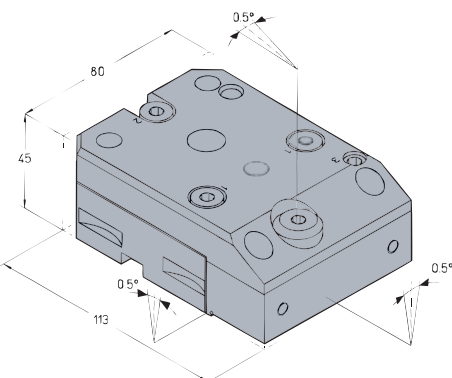

H4110 M 3D-Pallet (for M-Clamper)

H4110 P 3D-Pallet (for P-Clamper)

For manual and automatic changing of workpieces. Fits to P-Clamper and also to "B"-Beam and M-Clamper. Three axis levelling is standard, quick and easy workpiece alignment in X, Y and Z direction, when used on Presetting Work Station H 4900 or Presetting Cube H 4905, page 15.

Max. workpiece weight, workpiece holder included 30 kg (66.15 lbs)
Pallet weight 2.2 kg (4.8 lbs)

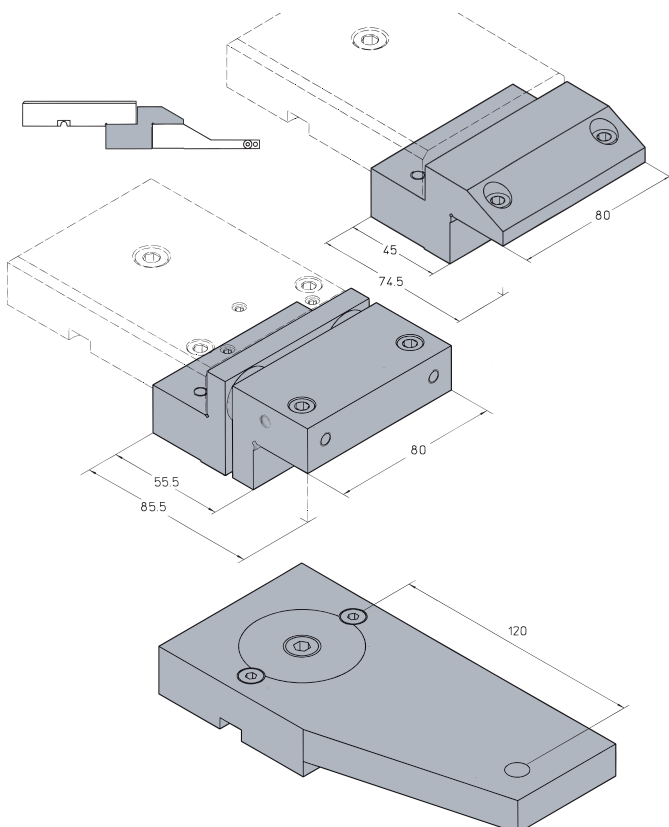

H4260 Pallet Extension Unit

The workpiece holder can be extended by 45 mm (1,76"). Recommended for use of vise H 4620.2.

H4250 Insulating Unit

For electrical insulation between Pallets H 4005, H 4105, H 4110 M/P and workpiece holders, to insulate workpiece against the machine table. Current is connected directly to the workpiece or to the lateral front part of insulating unit.

Max. workpiece weight, workpiece holder included 30 kg (66.15 lbs)
Unit weight 1 kg (2.20 lbs)

H4120 Reference Pallet

For referencing the coordinate position of the reference hole of H 4120 from the measuring machine to the Wire EDM and for alignment and check the position of clampers at the longitudinal side of the reference pallet, rectangular ground to the positioning Vee block.

This Reference Pallet avoid reference movements of the machine.

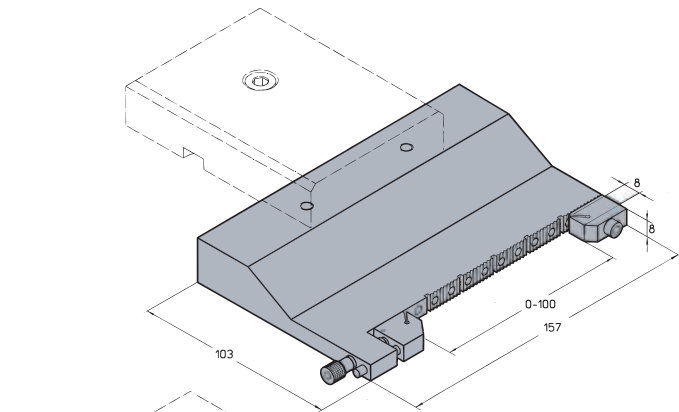

H4620.2 "Mighty" Mini Vise

Small "Toolmakers" vise for workpieces up to 100 x 60 x 12 mm (3.94 x 2.36 x 0.47").

End stop is positioned for securing various workpiece sizes. No reference bore.

Clamping range	0 - 100 mm (0 - 3.94")
Maximum workpiece weight with max. depth of 60 mm (2.362")	3 kg (6.6 lbs)
Weight of the vise	1.9 kg (4.2 lbs)

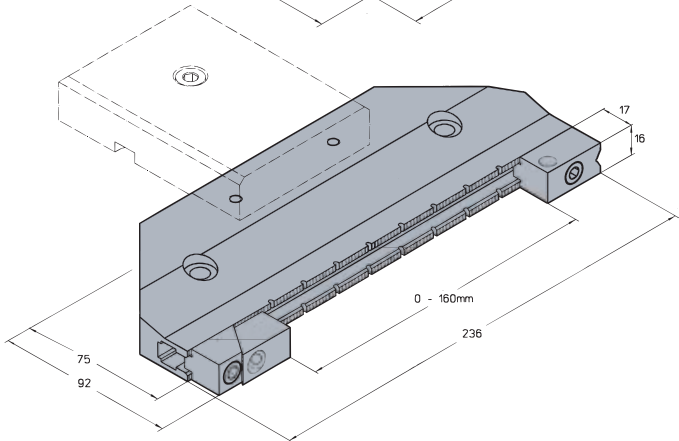

H4620.3 "Mighty" Thin Vise

The sturdy "Toolmakers" vise provides collision-free horizontal clamping of square or rectangular parallel workpieces.

Clamping jaw and end stop can be positioned anywhere along the scale. End stop can be turned around to clamp cylindrical parts in the horizontal Vee blocks.

Reference bore in the end stop helps to indicate position of the workpiece. The distance from the center of the bore to the contact surface is engraved on the vise.

Clamping range	0-160 mm (0" - 6.299")
Max. workpiece weight	5 kg (11.0 lbs)
Weight of the Vise	2.5 kg (5.50 lbs)

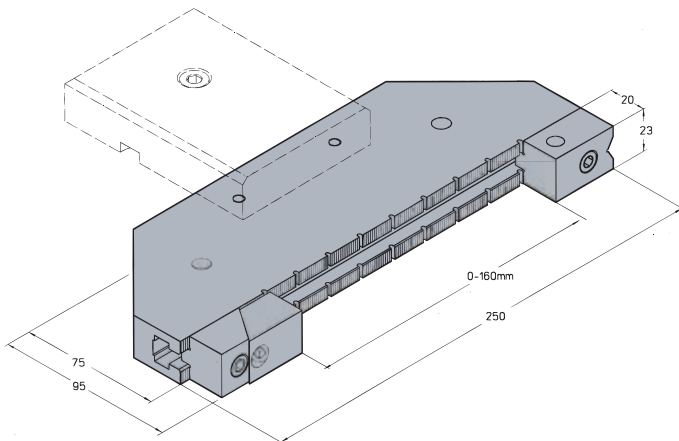

H4620 "Mighty" Vise

Same design as for H4620.3, but for larger workpieces with more weight.

Clamping range	0-160 mm (0" - 6.299")
Max. workpiece weight	15 kg (33 lbs)
Weight of the vise	3 kg (6.60 lbs)

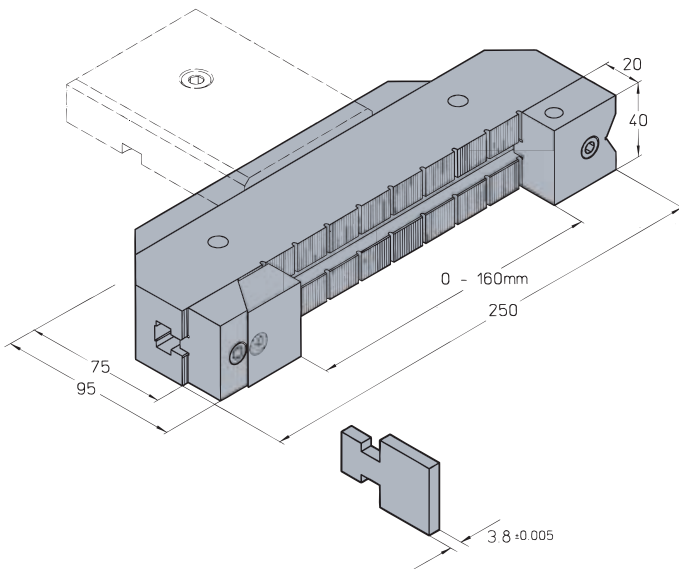

H4620.1 "Mighty" Vise

Same design as for H4620, but for workpieces with more weight.

Clamping range	0-160 mm (0" - 6.299")
Max. workpiece weight	30 kg (66.15 lbs)
Weight of the vise	4,5 kg (9.90 lbs)

H4620.DI Spacer (2 pcs.)

Allows clamping of two or three workpieces into Vice H4620.

H4620.1 DI Spacer for vice H 4620.1

H4620.3 DI Spacer for vice H 4620.3

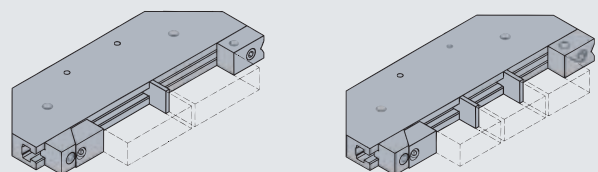

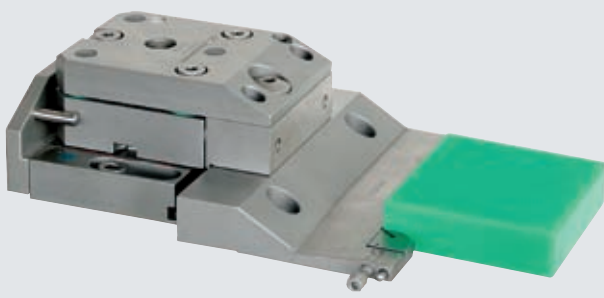

“Mighty” Mini Vise H 4620.2

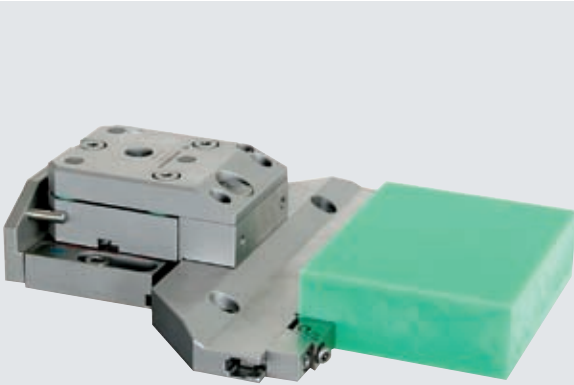

“Mighty” Thin Vise H 4620.3

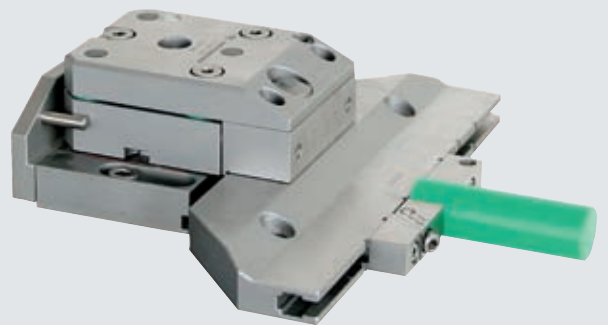

“Mighty” Thin Vise H 4620.3

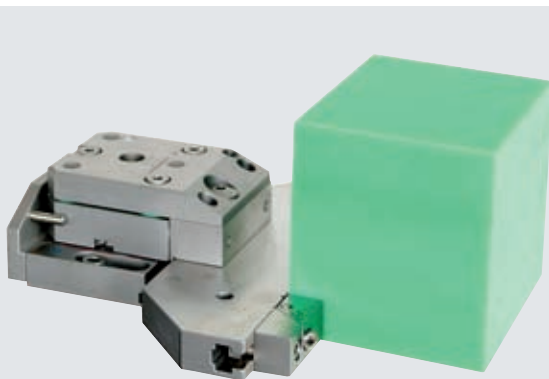

“Mighty” Vise H 4620

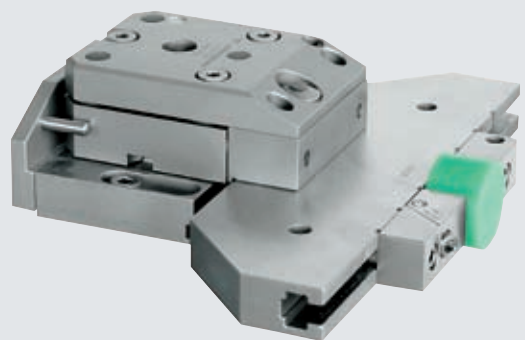

“Mighty” Vise H 4620

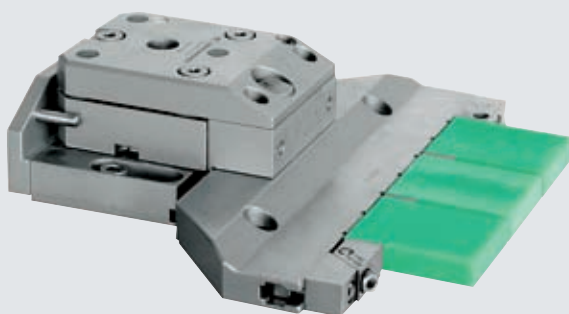

Vise H 4620.3DI
between separate workpieces

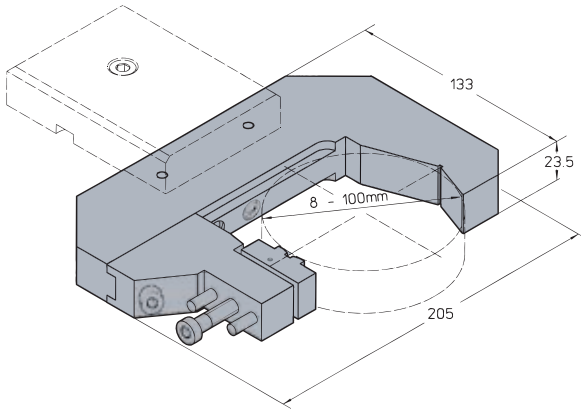

H4630 Prism Vise (Crawdad Claw)

The sturdy prism vise provides collision-free clamping of cylindrical workpieces.

The clamping jaw is positioned and secured in several positions allowing the full range of clamping.

Clamping range	Ø 8 – 100 mm (0.31– 3.94")
Max. workpiece weight	8 kg (17.6 lbs)
Weight of the prism vise	2.5 kg (5.5 lbs)

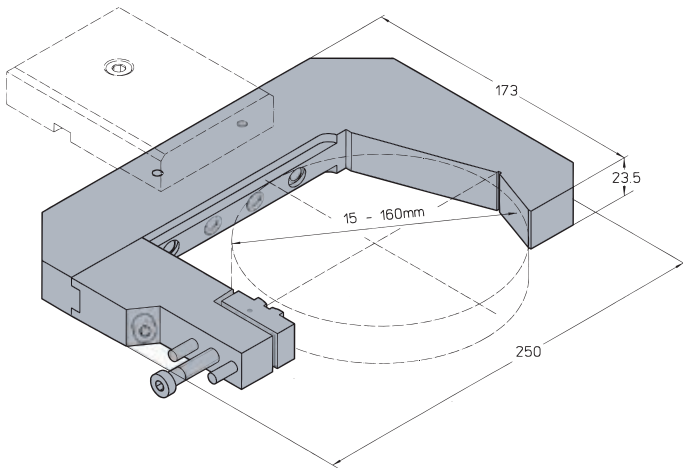

H4631 Prism Vise (Crawdad Claw)

Same design as for H4630, but for a larger clamping range and for a larger workpiece weight.

Clamping range	Ø 15 – 160 mm (0.59– 6.299")
Maximum workpiece weight	15 kg (33 lbs)
Weight of the prism vise	3 kg (6.61 lbs)

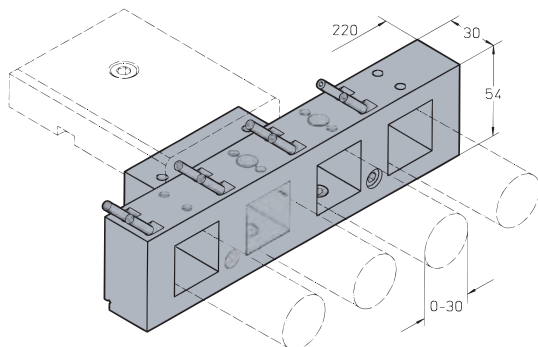

H4640 Prism Holder (4 pcs.)

For clamping cylindrical or rectangular workpieces up to Ø □ 30 mm (1.182").

The holder can be mounted in horizontal or vertical position on all pallets and via these it can be fixed on all clampers.

It can also be mounted directly on the cross beam.

Weight 2 kg (4.41 lbs)

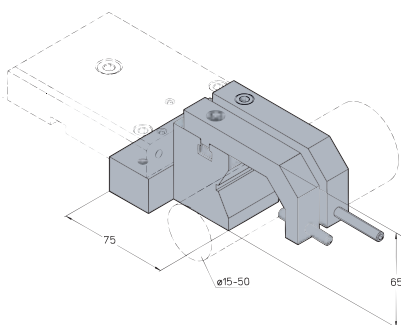
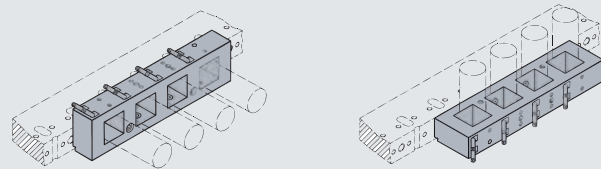

H4635 Prism Holder

For clamping cylindrical workpieces from Ø 15 to 50 mm (0.59 to 1.97").

Weight 2 kg (4.41 lbs)

H4636 Prism Holder

Similar to H4635 but with clamping range Ø 40 to 110 mm (1.576 to 5.91").

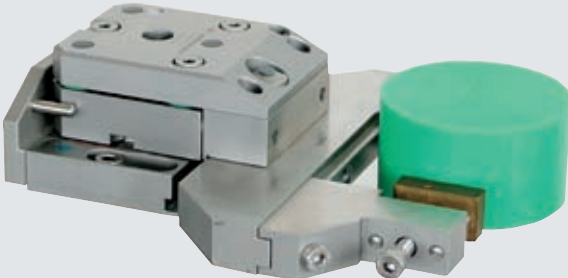

Prism Vise H 4630

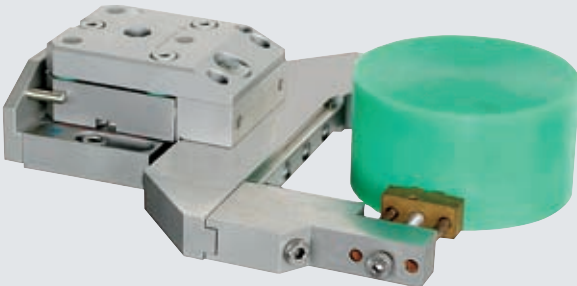

Prism Vise H 4631

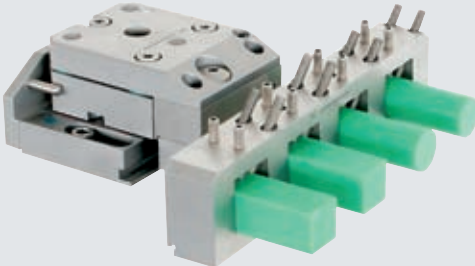

Prism Holder H 4640 (horizontal use)

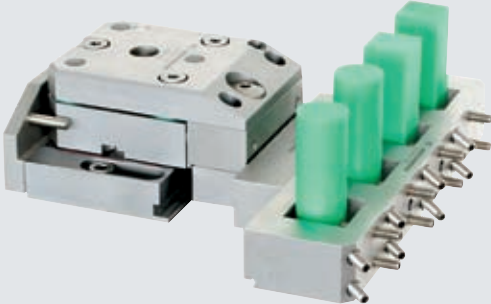

Prism Holder H 4640 (vertical use)



Prism Holder H 4635

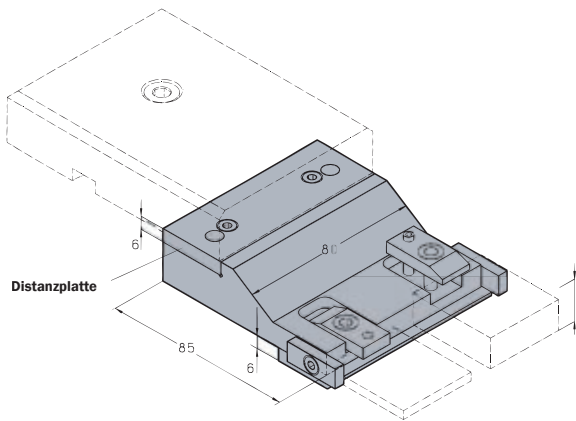

H4536 Vertical Vise

For mounting flat workpieces, up to 25 mm (0.985) in height.

With end stops on the side.

To avoid collision with the lower wire nozzle, the height of the workpiece support can be adjusted by using the distance plate (6 mm/0.236").

Clamping range	0 – 25 mm (0.985")
Max. workpiece weight	7 kg (15.44 lbs)
Weight of the chuck jaw	1.4 kg (3.0 lbs)

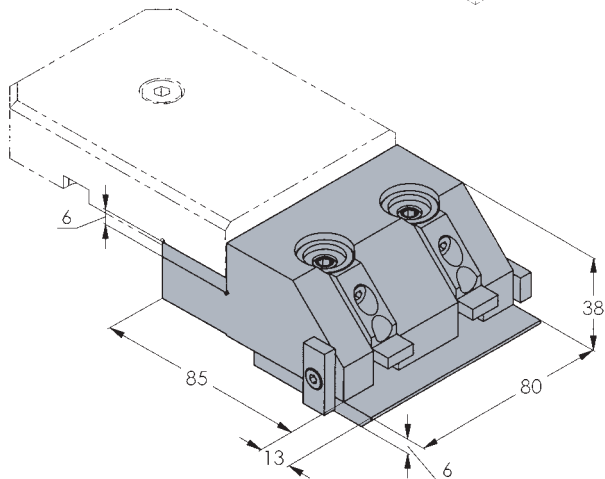

H4537 Vertical Vise

For mounting flat workpieces, up to 41 mm (1.615") in height.

With end stops on the side.

To avoid collision with the lower wire nozzle, the height of the workpiece support can be adjusted by using the distance plate (6 mm/0.236").

Clamping range	0 – 41 mm (1.615")
Max. workpiece weight	15 kg (33.07 lbs)
Weight of the chuck jaw	1.7 kg (3.75 lbs)

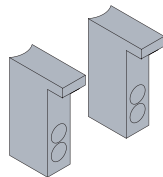

H4537.E Clamping Insert

Via clamping insert H4537.E clamping height of vertical vise H4537 can be increased to 60 mm (2.364").

Delivered as set with 2 inserts.

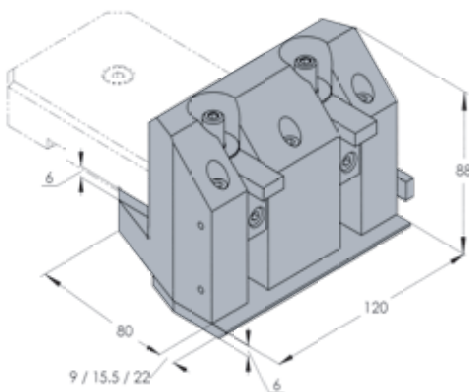

H4538 Vertical Vise

For mounting workpieces, up to 115 mm (4.53") in height. With end stops on the side. Workpiece support can be adjusted to overhang 9 mm (0.355"), 15,5 mm (0.61") or 22 mm (0.867").

To avoid collision with the lower wire nozzle, the height of the workpiece support can be adjusted by using the distance plate (6 mm/0.236").

Clamping range	20–115 mm (0.79–4.53")
Max. workpiece weight	30 kg (66.15 lbs)
Weight of the chuck jaw	4.7 kg (10.36 lbs)

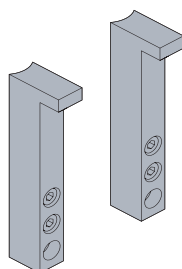

H4538.E Clamping Insert

Via clamping insert H4538.E clamping height of vertical vise H4538 can be increased to 160 mm (6.3").

Delivered as set with 2 inserts.

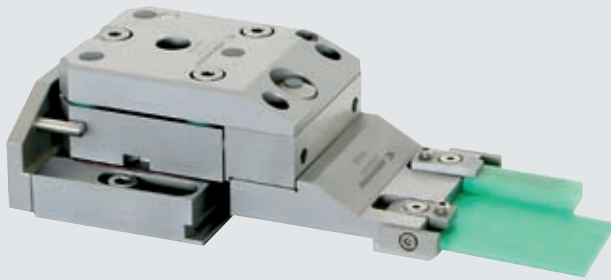

Vertical Vise H 4536

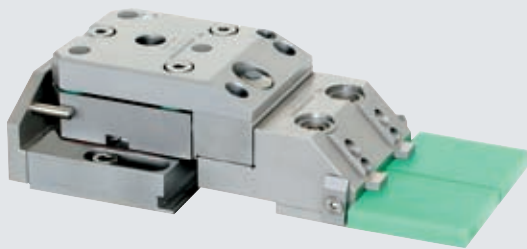

Vertical Vise H 4537

Clamping range 0 to 41 mm
(0" - 1.615")

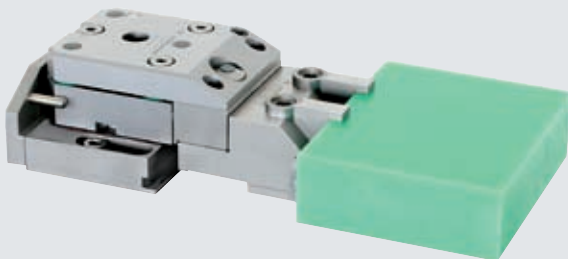

Vertical Vise H 4537

Clamping range 41 to 60 mm
(1.615" - 2.364")

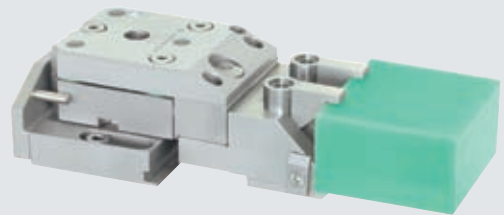

Vertical Vise H 4537 with Clamping Insert H 4537E

Clamping range 20 to 115 mm
(0.79" - 4.53")

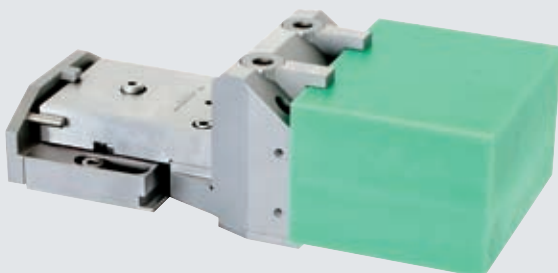

Vertical Vise H 4538

Clamping range 115 to 160 mm
(4.53" - 6.3")

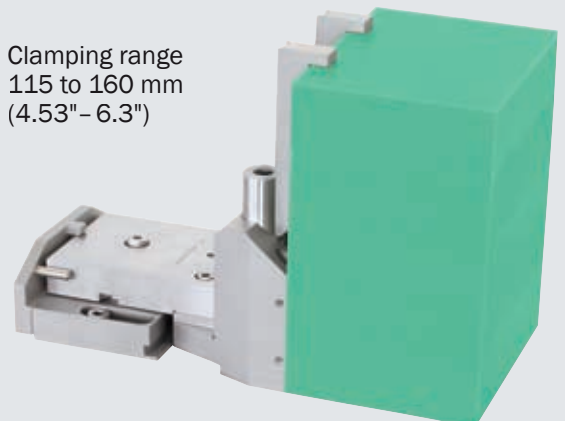

Vertical Vise H 4538 with Clamping Insert H 4538.E

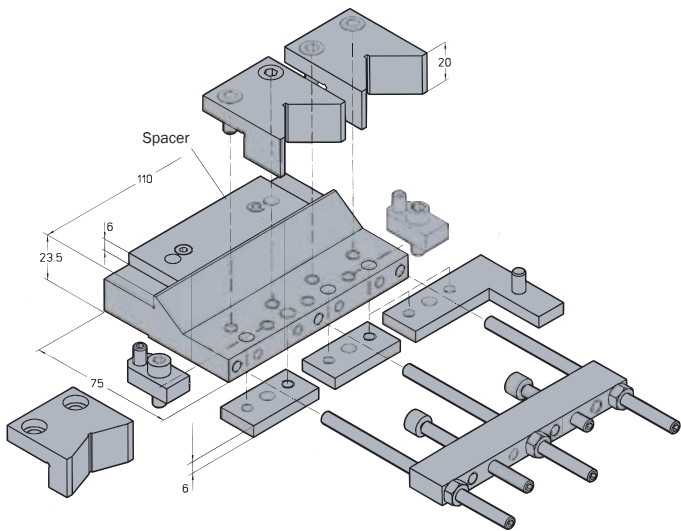

H4230 Small Uniholder

This universal workpiece holder can be used for clamping and positioning round, square or rectangular workpieces in the cutting area of the machine.

It is customary to clamp the workpieces outside the machine, on the Presetting Work Station H 4900 or on the Presetting Cube H 4905, and to align them there.

To avoid collision with the lower wire nozzle, the workpiece support can be adjusted by using the distance plate (6 mm/0.24" dia.).

Like all workpiece holders, the uniholder can be used for automatic machine loading with the Pallets H 4105.

Max. permissible workpiece weight 3 kg (6.61 lbs)
 Weight of the uniholder depends on parts used 1 - 1.3 kg (2.20 - 2.86 lbs)

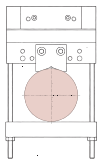

Ø 90 mm

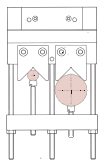

Ø 42 mm

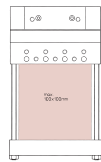

100 x 100 mm

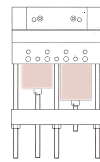

80 x 42 mm

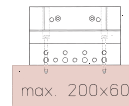

max. 200x60

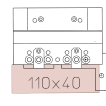

110x40

Like all workpiece holders, the uniholder can be used for automatic machine loading with the Pallets H 4105 and H 4110 P.

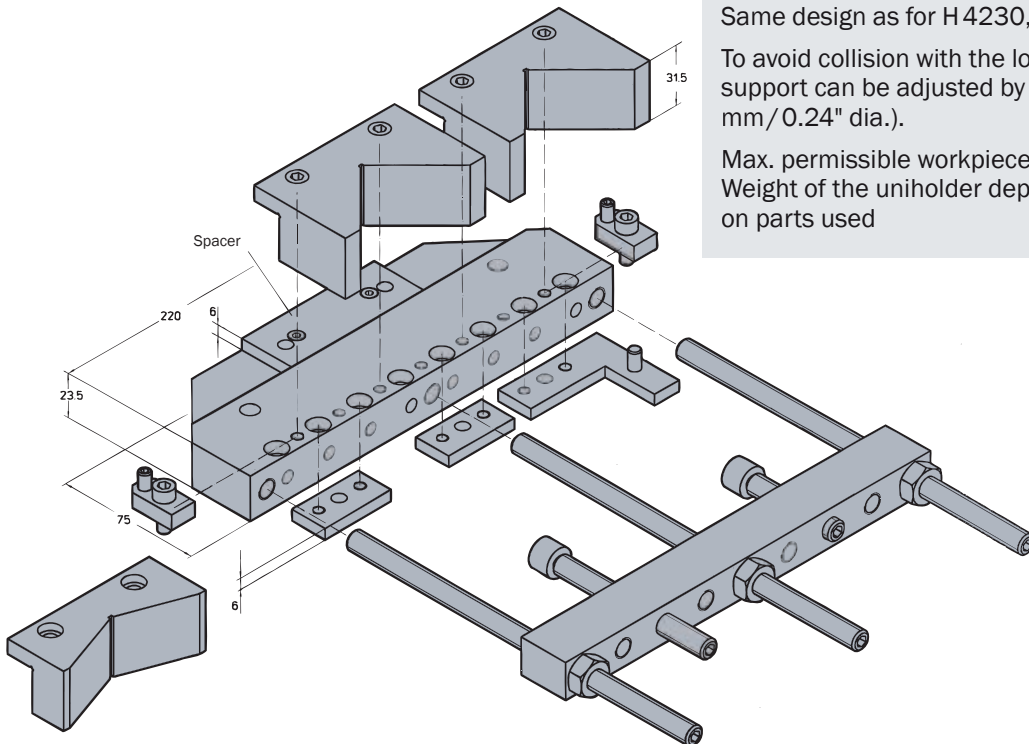

H4231 Large Uniholder

Same design as for H 4230, but for larger workpieces.

To avoid collision with the lower wire nozzle, the workpiece support can be adjusted by using the distance plate (6 mm/0.24" dia.).

Max. permissible workpiece weight 12 kg (26.45 lbs)
 Weight of the uniholder depends on parts used 2.1 - 3.5 kg (4.62 - 7.71 lbs)

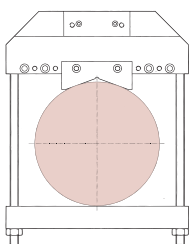

Ø 160 mm

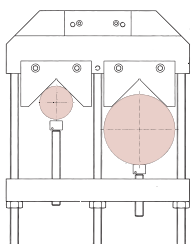

Ø 85 mm

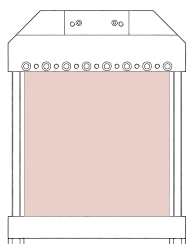

180 x 170 mm

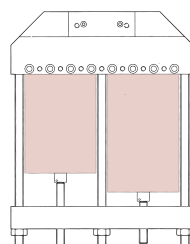

145 x 85 mm

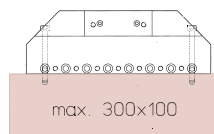

max. 300x100

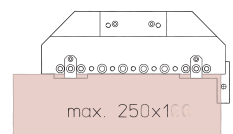

max. 250x110

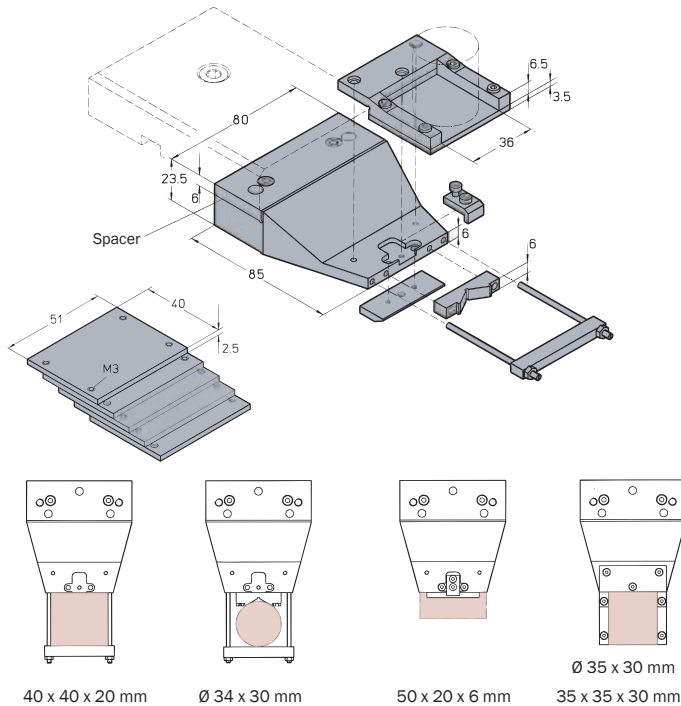

H 4232 Mini-Holder

Universal holder for small workpieces. Similar design as for the uniholders.

An additional small support holder with Aluminium Support Plates H 4232.1 is used for small workpieces up to 35 x 35 mm (1.38" x 1.38") to be bonded to and for their peripheral machining.

The Single-package System H 50 K is to be used for bonding.

To avoid collision with the lower wire nozzle, the workpiece support can be adjusted by using the distance plate (6 mm / 0.24").

Weight of the Mini-Holder depends on parts used approx. 1 kg (2.20 lbs)

Delivery includes 5 Aluminium Support Plates H 4232.1.

H 4232.1 Aluminium Support Plates (5 pcs.)

Additional aluminium support plates for the support holder of the Mini-Holder H 4232.

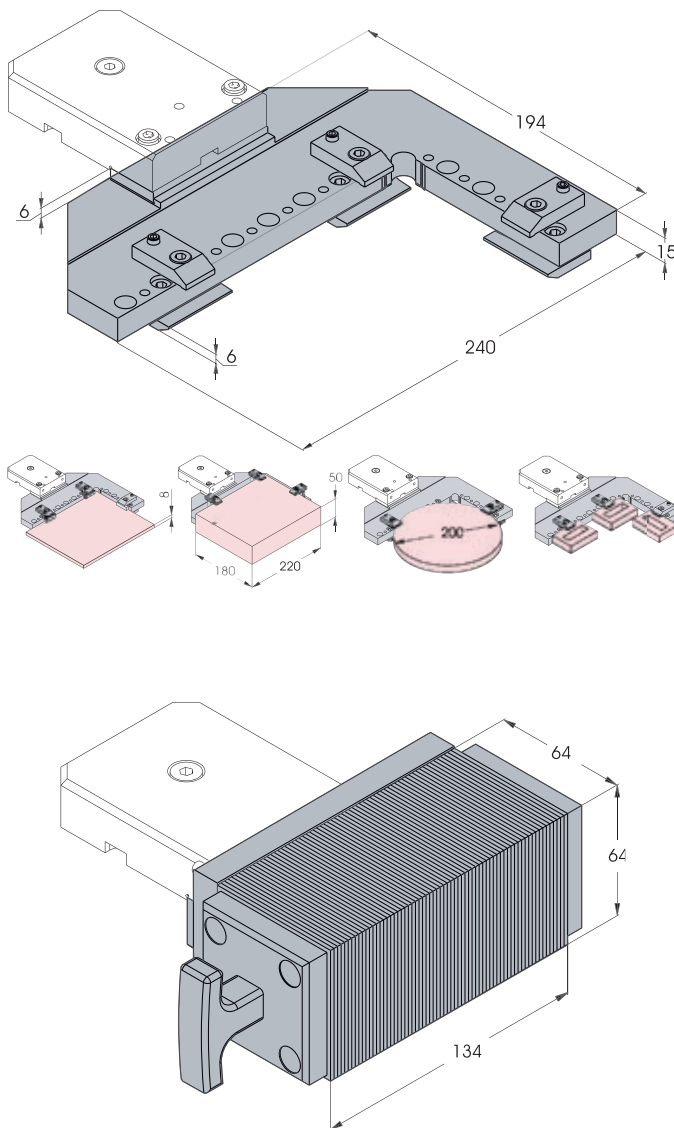

H 4225 Clamping Angle

Universal holder for collision-free clamping of rectangular and cylindrical workpieces with a weight up to 30 kg.

To avoid collision with the lower wire nozzle, the workpiece support can be adjusted by using the distance plate (6 mm / 0.24").

Max. workpiece size 220x180 mm/Ø 200 mm (8.7x7.1"/ Ø 7.9")

Weight approx. 3 kg (6.60 lbs)

H 4270 Magnet-Holder

Universal magnet holder for collision-free clamping of rectangular workpieces.

Holding force 50 N/cm²

Weight approx. 5 kg (11 lbs)

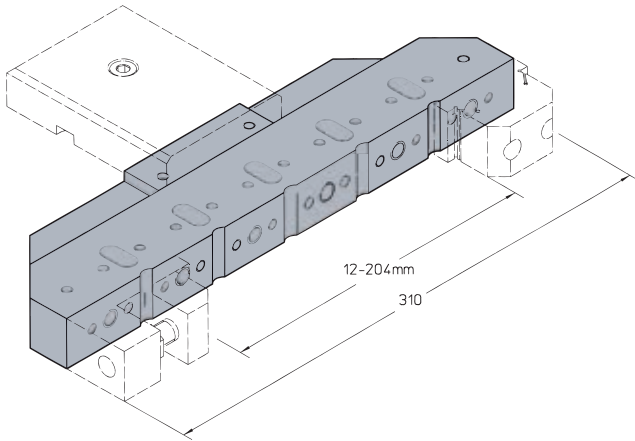

H4233 Basic Holder

This Basic Holder is the small version of the cross beam. It is placed with a pallet directly on the Clamper. For example, Beam Vise Kit can be mounted to front surface.

The presetting of the workpiece should be done on a granite surface plate or on the presetting work station.

Max. workpiece weight of parallel workpieces with a maximum depth of 130 mm (5.12") 30 kg (66.15 lbs)
 Weight of the Basic Holder 6 kg (13.23 lbs)

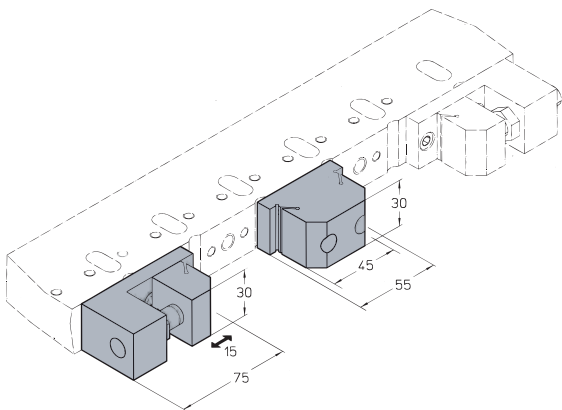

Beam Vise Kit consisting of:

H4312 Solid Jaw, H4312.1 Clamper

For collision-free clamping of parallel workpieces directly on the cross beam. Larger cylindrical workpieces are clamped against the second cross beam using the bevelled faces (secured by the Adjustable End Stop H4320). The presetting of the workpiece should be done on a granite surface plate.

Max. workpiece weight of parallel workpieces with a max. depth of 130 mm (5.12") 30 kg (66.15 lbs)
 Max. workpiece weight with support plate at opposite cross beam 100 kg (220.46 lbs)
 Max. workpiece weight of cylindrical parts against second cross beam, with 2 end stops 30 kg (66.15 lbs)

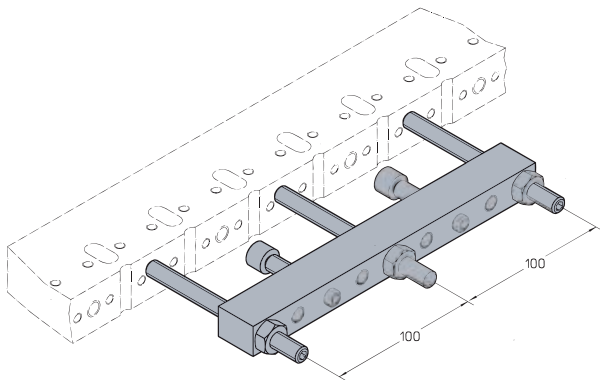

H4331 Clamping Beam

For collision-free clamping of rectangular workpieces and, supplemented by the set of Vee blocks, also for collision-free clamping of cylindrical workpieces, directly on the cross beam/basic holder.

If a Uniholder H4231 is provided, the clamping beam is not required, as these parts are already contained in the uniholder.

Max. permissible workpiece weight 8 kg (17.64 lbs)

H4331L Clamping Beam

Clamping beam with long threaded rods (see page 24).

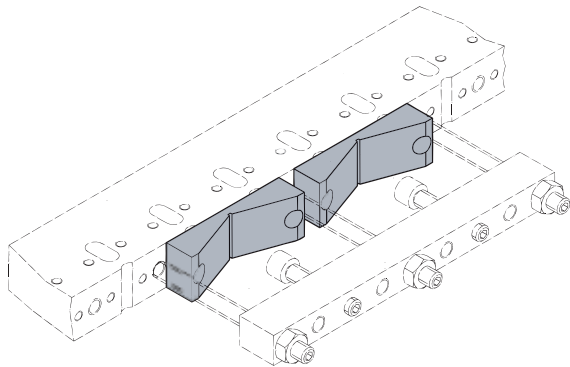

H4332 Set of Vee Blocks (2 pcs.)

For clamping cylindrical workpieces with the Clamping Beam H4331.

Preliminary setting of the workpiece should be done on the granite surface plate.

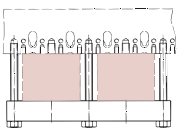

2 x 85x60

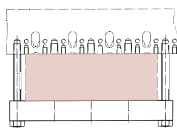

185 x 60

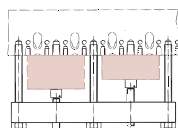

2 x 85x50

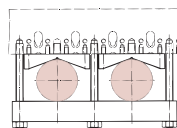

2 x ø55

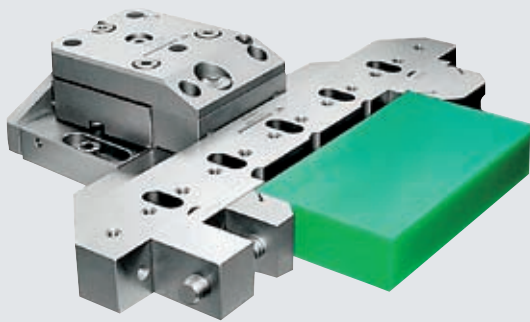

Basic Holder H4233 together with Beam Vise Kit
H4312/H4312.1

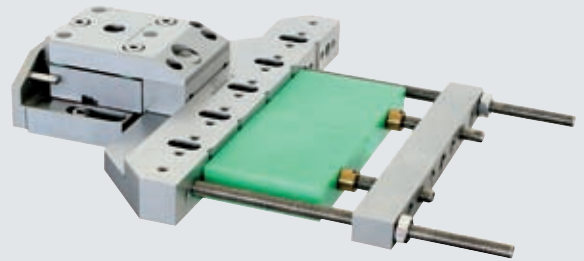
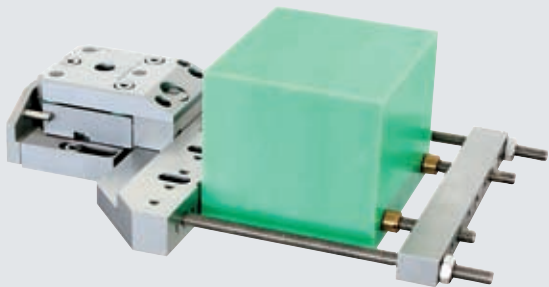

Basic Holder H4233 together with Clamping Beam H4331L

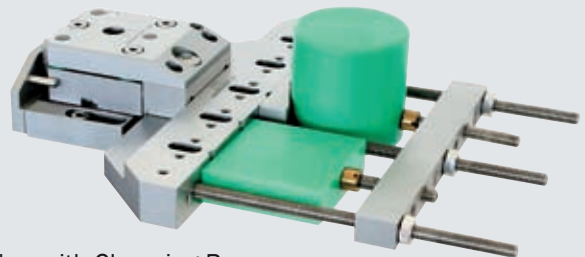
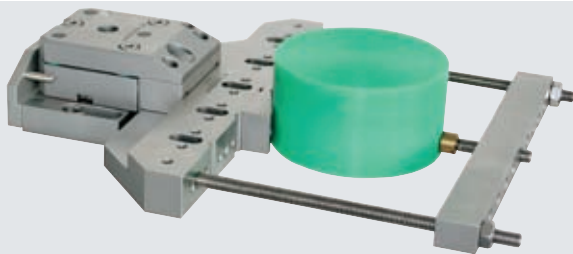

Basic Holder H4233 together with Clamping Beam
H4331L and Vee Block Set H4332

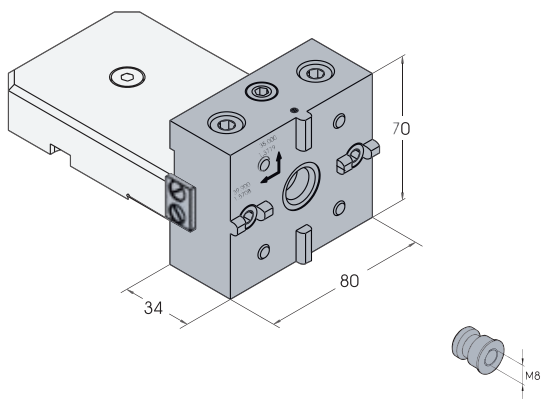

H4202 Pallet Clamper

For clamping pallets and electrode holders of the Fixturing System 5000 for Sinking EDMs.

Can be mounted on the face side of a M- or P-Pallet, vertically or horizontally to a Swivelling Unit H4420, to the Vertical Unit H4410 and to the Adapter H4421.

The position of Vee block center to the exterior surfaces is engraved on the face but can also be found with the Reference Pallet H4203.

Weight 1.3 kg (2.9 lbs)

H4205 Adapter Peg

for fixing the pallets H4005, H4105 and H4110 M/P in the Pallet Clamper H4202 .

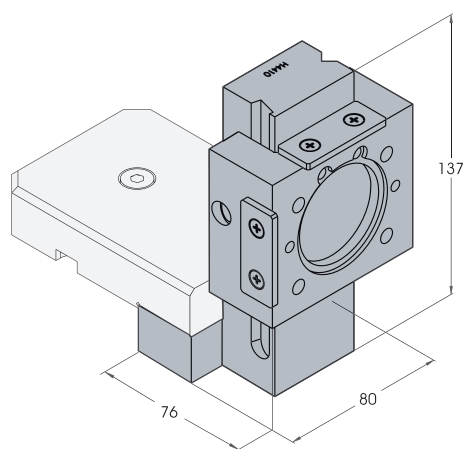

H4410 Vertical Unit

Vertical unit with variable height adjustment is used with Pallets H4005, H4105 or H4110 M/P.

A Swivelling Unit H4420, a Pallet Clamper H4202 (vertically and horizontally) or an Adapter H2495 can be mounted to the front surface.

Adjustment range: 65 mm (2.56")
Weight 1.7 kg (3.7 lbs)

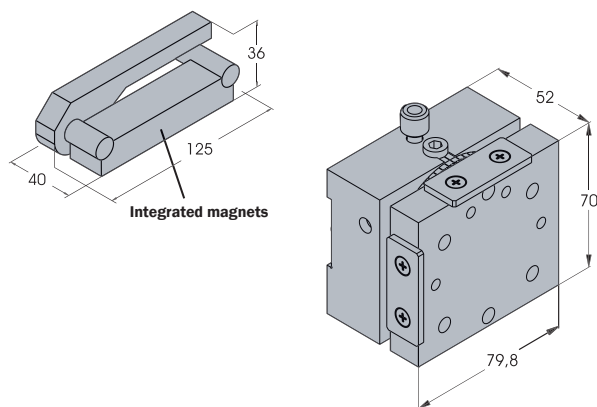
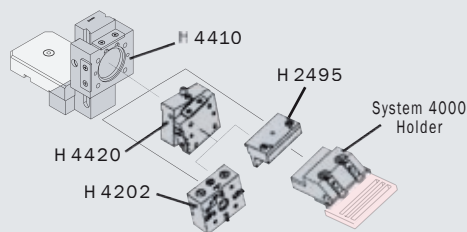

H4416 Sine Bar

For precise setting of the Swivelling Unit H4420.

H4420 Swivelling/Indexing Unit

Mountable directly to the Vertical Unit H4410, the Adapter H4421 or to the Pallet H4005, H4105 and H4110.

A Pallet Clamper H4202 or an Adapter H2495 can be mounted to the front surface.

Indexing range: $\pm 90^\circ$ in 5° steps.
Continuously swivelling range 360°
(can be set and locked via the vernier scale or a Sine Bar H4416)
Weight 2 kg (4.4 lbs)

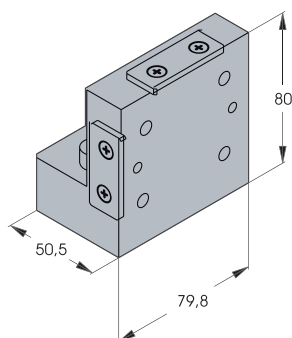

H4421 Mounting Angle

The H4421 is the link between the machine table and the Swivelling Unit H4420, the Pallet Clamper H4202 (vertically and horizontally) or the Adapter H2495.

Weight 1.3 kg (2.9 lbs)

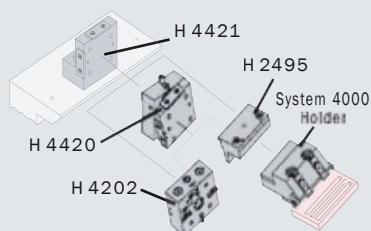

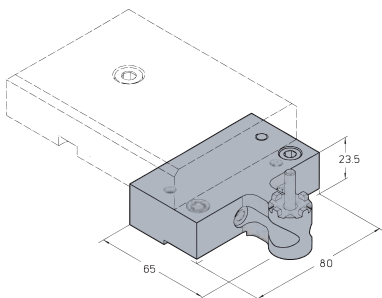
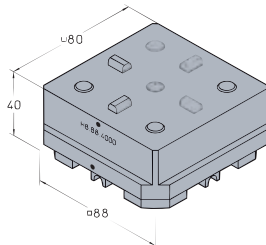
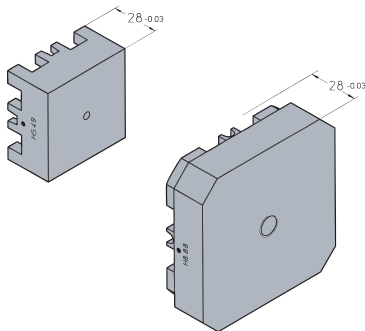
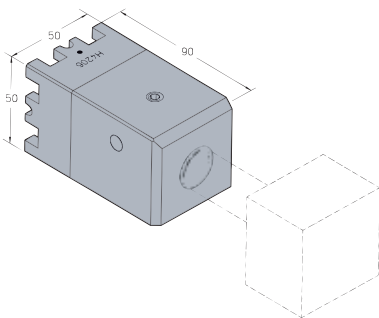
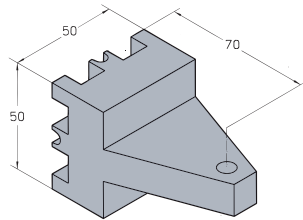
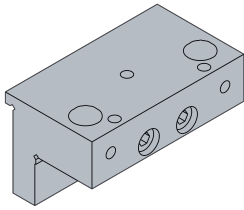

H2495 Adapter

The adapter is the link between the Vertical Unit H4410, the Swivelling Unit H4420 or the Mounting Angle H4421 and all holders of the Fixturing System 4000.

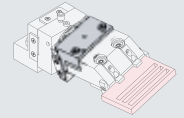

H4203 Reference Pallet

For determining the central position of the Pallet Clamper H4202 and of A-Axis H80R.NC.

H4206 Shaft Clamping Chuck

For mounting and precise indexing and clamping of the electrode shafts of Fixturing System 5000. The chuck fits, like all other pallets and electrode holders of System 5000, to Pallet Clamper H4202. Weight 2 kg (4.4 lbs)

H5.50R Pallet

Rust-proof pallet 50 x 50 mm (1.97 x 1.97") for mounting electrodes and workpieces. Please order Clamping Journal H 5.611R or H 6.611R separately.

H8.88R Pallet

Rust-proof pallet 88 x 88 mm (3.46 x 3.46"), for mounting electrodes and workpieces. Please order Clamping Journal H 5.611R or H 6.611R separately.

H5.611R Clamping Journal (stainless)

H5.611.1R Centering Bush (stainless)

for clamping of pallets and holders in the H4202 Pallet Clamper and in the H8.. series clamper of the Fixturing System 5000.

H6.611R Clamping Journal (stainless)

for clamping the pallets and holders in the H6.. series clamper of the Fixturing System 5000.

H8.88.4000 Adapter for System 5000

Adapter to mounting the pallets H4005, H4105, H4110M and H4110P to clampers of the Fixturing System 5000. Please order Clamping Journal H5.611R or H6.611R separately.

H4246 MINIFIX Holder

For direct mounting of MINIFIX- and MINIFIXplus electrodes of System 5000 on a Wire EDM.

The holder fits on Pallets H4005, H4105 and H4110M/P, but can also be attached to the Vertical Unit H4410 and the Swivelling Unit H4420.

Weight 1 kg, (2.2 lbs)

Example for use at Vertical Unit H4410

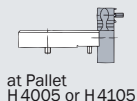
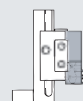
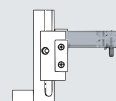

at Pallet H4005 or H4105

Special holders

customized for special clamping problems

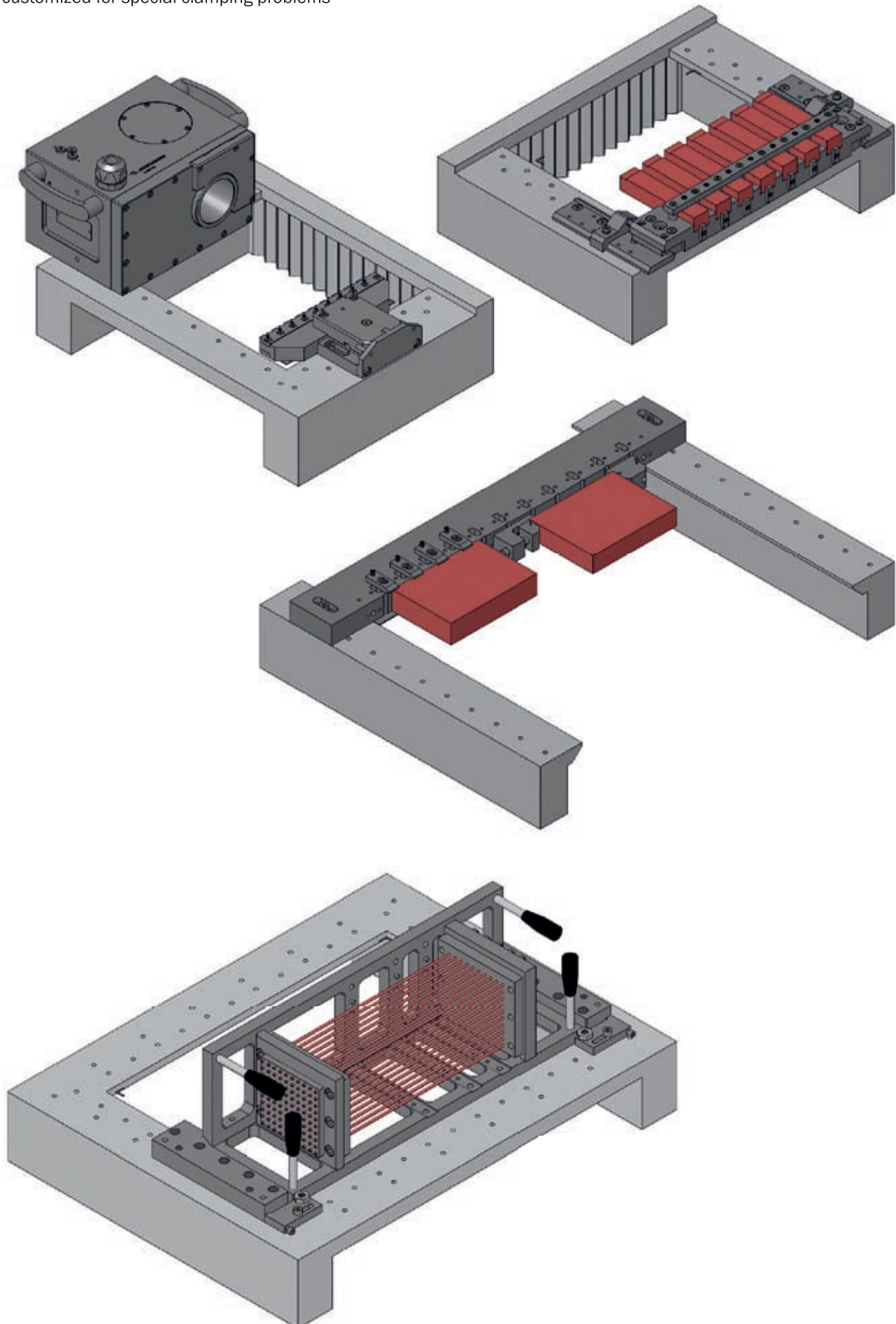

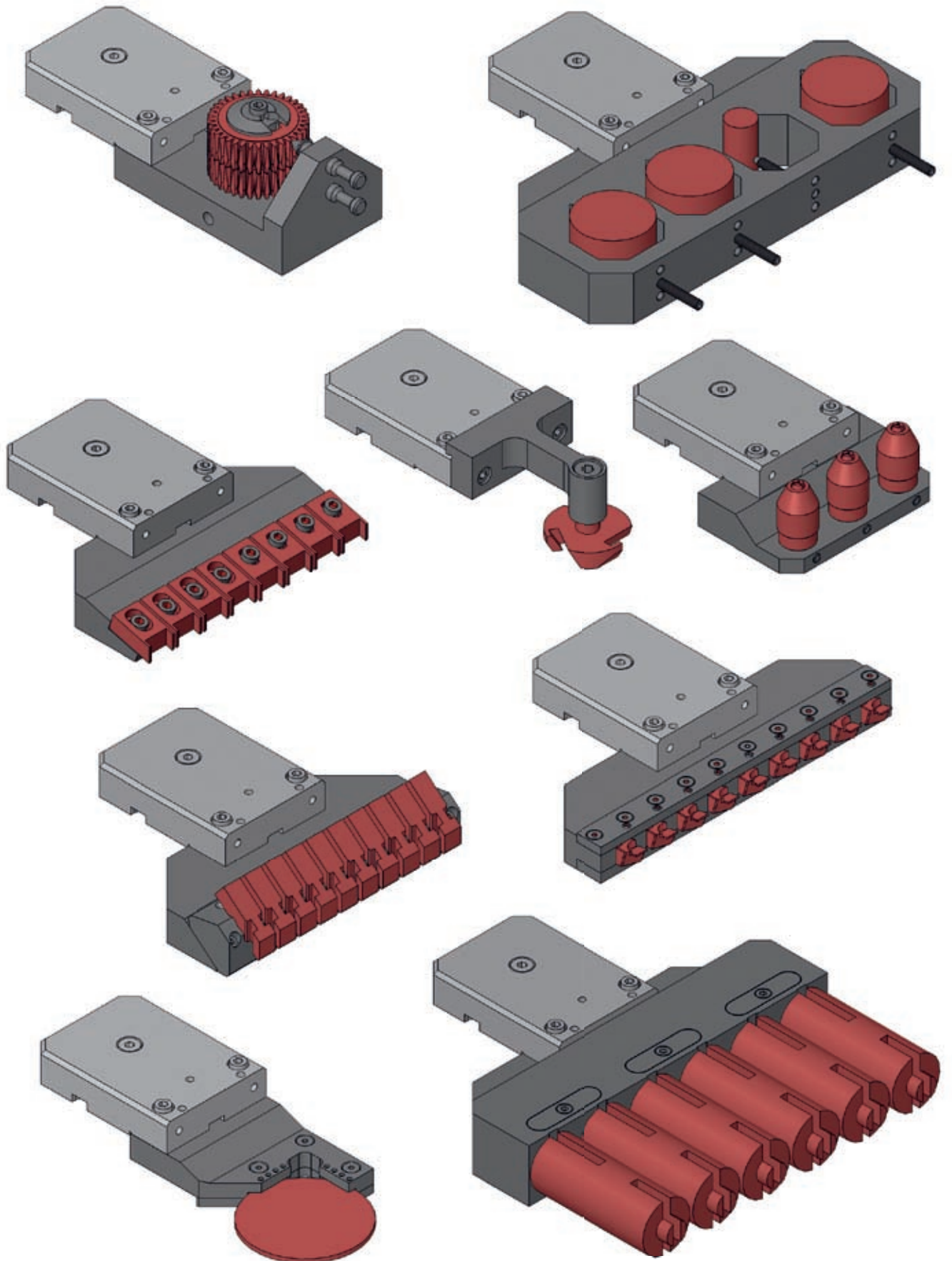

High Speed Rotating Spindle H 80R.MAC

High speed rotary spindles open new possibilities in spark erosion production. They enable erosion “turning” of the smallest parts with high surface quality (Ra 0.1 mm and better) not possible with conventional machining. (Lathes and grinding machines) This is now possible with HIRSCHMANN high speed rotary spindles.



H 80R.MAC Rotating Spindle

with manual clamper H 8.16R (for clamping journal H 5.611R).
Rust-proofed, maintenance free AC-Drive.

Dimensions (WxDxH) 190/191/98 mm (7.5/7.52/3.9")
Speed 0–1500 min⁻¹
Axial accuracy ≤ 0,003 mm (0.00012")

H 80R.MAC.6 Rotating Spindle

Similar to H 80R.MAC but with manual clamper H 6.16R (for clamping journal H 6.611R).

H 80R.MAC.44 Rotating Spindle

Similar to H 80R.MAC but equipped with adapter disc for mounting the Adjustable Clamping Elements H 5.83.46R-xx.

H 1680.AC4 Speed Control Unit

for speed control of the H 80R.MAC.. Rotating Spindles.

H 1680.AC4I1 Speed Control Unit

Same as H 1680.AC4 but including a interface for automatic start and stop of the spindle via the machine control (M-code).

High Speed Rotating/Positioning Spindle H 80R.MNC

The H 80R.MNC high speed rotating and indexing spindle allows complete production of complex parts in the same set-up. Depending on the machine control the axes can be integrated directly to the machine control for indexing, spinning or simultaneous multi-axis erosion (turn while burn). If direct integration is not possible, high speed rotation and indexing can be controlled through the HIRSCHMANN H 1625.AC3 control with communication to the machine via M-code.



Rotating/Positioning Spindle with clamper

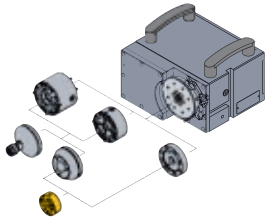

H 80R.MNC.. Rotating/Positioning Spindle

Rust-proof, long-life AC drive

Dimensions (W/D/H) approx. 265/212/120 mm
(10.43/8.35/4.72")

Speed 0-1000 min⁻¹

Indexing accuracy (direct measuring system) ± 5"

Axial accuracy ≤ 0,003 mm

Loading weight max. 30 kg

Design versions

- face-plate Ø 80 mm
- manual clamper H 6.16R, H 8.16R
- pneumatic clamper H 6.11.10R, H 8.11.10R
- support for adjustable clamping element H 5.83.46R-xx
- clamper of other manufacturers

H 1625.AC3 Control

for Rotating/Positioning Spindle H 80R.MNC..

Dimensions (W/D/H) 520/420/230 mm (19.3/15.8/9")

Power supply 230 V 50/60 Hz

For further information please see our catalogue
“Rotary Indexing Tables, A-Axes and Rotating Spindles”

Adjustable Clamping Element H 5.83.46R – erosion grinding with high precision

High accuracy requires a precise concentricity. With the HIRSCHMANN Adjustable Clamping Element the concentricity can be quickly and easily adjusted to < 0.001 mm.

The adjustment of the run-out can be done in the Rotating Spindle or external in a Presetting Spindle (demands the Clamping Element Holder and use of a Rotating Spindle with clamper).

Features

- Adjustable Runout Accuracy of < 0.001 mm
- Clamping diameter \varnothing 1 mm - 20 mm (other in planing)
- all parts are rust-proofed



Presetting with Presetting Spindle and Adjustable Clamping Element

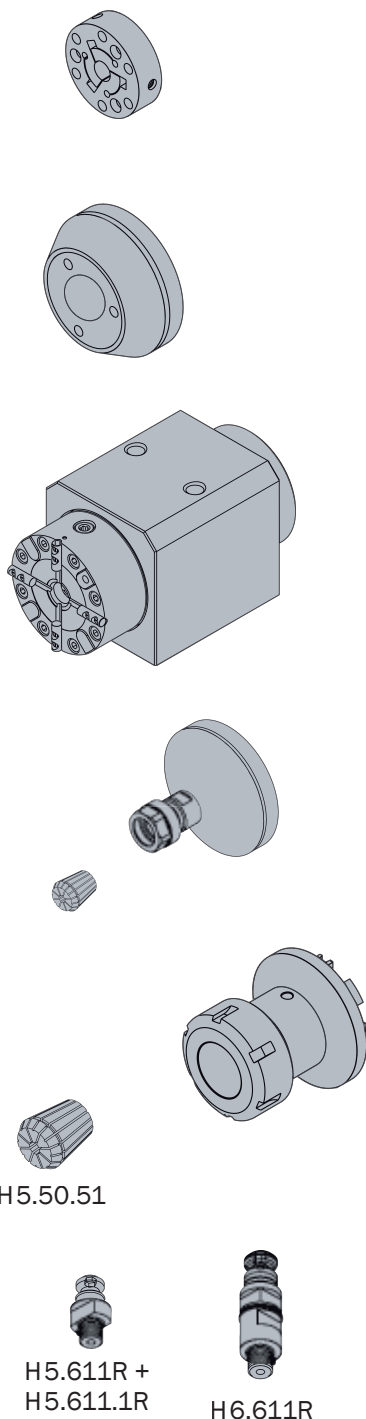

H5.83.46R-xx Adjustable Clamping Element (Brass)
for the precise adjustment of the workpiece concentricity. The Adjustable Clamping Elements are mounted to the Clamping Element Holder H 5.83.45R or directly to the Rotating Spindles resp. A-Axes equipped with Adjustable Clamping Elements.
Concentricity adjustable to < 0.001 mm
Clamping range (xx) from \varnothing 1 mm until \varnothing 20 mm
(When ordering, please state the exact clamping diameter (xx))

H5.83.45R Clamping Element Holder (stainless)
for mounting the Adjustable Clamping Elements H 5.83.46R-xx in the Rotating Spindles, Axes and Presetting Spindles with HIRSCHMANN clampers.
Please order Clamping Journal H 5.611R resp. H 6.611R separately!

H5.83.60R Presetting Spindle (Clamper H 8.16R)
to preset the concentricity of the parts which are clamped in the Adjustable Clamping Element H 5.83.46R and mounted to the Clamping Element Holder H 5.83.45R.
Concentricity \leq 0,002 mm

H6.83.60R Presetting Spindle (Clamper H 6.16R)
similar to H 5.83.60R but with Clamper H 6.16R

H5.83.40R.MAC Collet Holder (stainless)
Clamping nut nickel plated. For collet H 50.41.
Concentricity (without collet) 0,005 mm
Please order Clamping Journal H 5.611R resp. H 6.611R separately!

H50.41 Collet ER/ESX 16 (non stainless)
Clamping range infinitely variable from \varnothing 0.5 - \varnothing 10 mm.
Collet size from \varnothing 1 - \varnothing 10 mm, in 1 mm increments.
Radial deviation until \varnothing 5 mm = 0.01, from \varnothing 6 mm = 0.02 mm
Stainless edition on request.

H5.83.50R Collet Holder (stainless)
Clamping nut nickel plated. For collet H 5.50.51 (ER40).
Clamping range \varnothing 3 - \varnothing 26 mm.
Concentricity (without collet) 0,01 mm
Weight 1,1 kg
Please order Clamping Journal H 5.611R resp. H 6.611R separately!

H5.611R Clamping Journal and H5.611.1R Centering Bush (stainless)
to use the holders in the clamper H 8... series.

H6.611R Clamping Journal (stainless)
to use the holders in the clamper H 6... series.

Rotary Tables and A-Axes for use on Wire and Sinking EDM

Common Characteristics

- stainless steel case, completely sealed (IP68)
- high positioning accuracy by direct measuring system
- AC or DC drive
- vertical and horizontal use

- dividing accuracy up to 0.001 degrees
- smallest dividing step 0.0001 degrees
- radial run-out < 0.005 mm
- closed loop measurement



H 80R.NC... A-Axis

with manual or pneumatic pallet clamber for mounting holders and pallets of Fixturing Systems 4000 and 5000.

Dimensions w/d/h approx. 230/230/130 mm
(9.062/9.062/5.122")



H 100R.NC... A-Axis

Rotary plate attached insulated to case.

Workpiece clamping plate (rotary plate) Ø 100 mm (3.94")
Dimensions w/d/h approx. 230/230/130 mm
(9.062/9.062/5.122")



H 150R.NC... A-Axis

Taper shaft support with manual or pneumatic cone shaft clamber.

Taper shaft support SK 50 or HSK 63F
Dimensions w/d/h approx. 230/215/160 mm
(9.062/8.392/6.304")



H 100R.NC Rotary Indexing Table

For workpieces weighing up to 50 kg

Workpiece clamping plate (rotary plate) Ø 100 mm (3.94")
Dividing accuracy ± 20"
Dimensions w/d/h approx. 185/215/135
(7.29/8.39/5.32")



H 160R.NC, H 250R.NC Rotary Indexing Table

For workpieces weighing up to 250 kg

Workpiece clamping plate (rotary plate) Ø 160 mm (6.3")
or Ø 250 mm (9.85")
Dimension H 160 W/D/H ca. 265/149/203mm (10.4/5.9/8")
Dimension H 250 W/D/H ca. 340/135/290 mm (13.4/5.3/11.4")



H 1625... CNC Control

Free programmable straight-line control

Power supply 115/230 V 50/60 Hz
Dimensions W/D/H ca. 520/420/230 mm

For further information please see our catalogue
"Rotary Indexing Tables, A-Axes and Rotating Spindles"

Automatic workpiece changing

HIRSCHMANN produces and supplies handling units as well as complete manufacturing cells equipped with magazine positions, 6-axis-robots and process control software for loading one or several machines.



EROBOT 40xx

Automatic workpiece changer for single machine operation. Design and equipment on request.

Transfer weight

30 kg (67 lbs)

Magazine positions

up to 15

(other designs on request)



Robot-Cell

HIRSCHMANN designs, produces and delivers ready to use and customer-specific robot cells with electrode and workpiece magazines for loading one or several machines. Design and equipment on request.

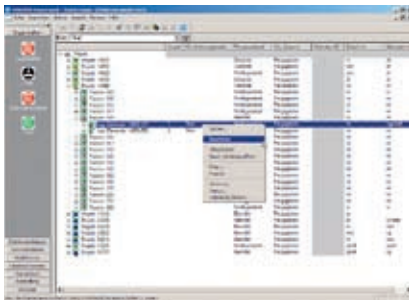

Process Control Software

PC-based process control system for the supervision, control, management and visualisation of manufacturing cells. It enables a comfortable survey and control of all production orders and machine status, allows quick reaction on amendments in job processing and ensures the economic use of one or several machines.

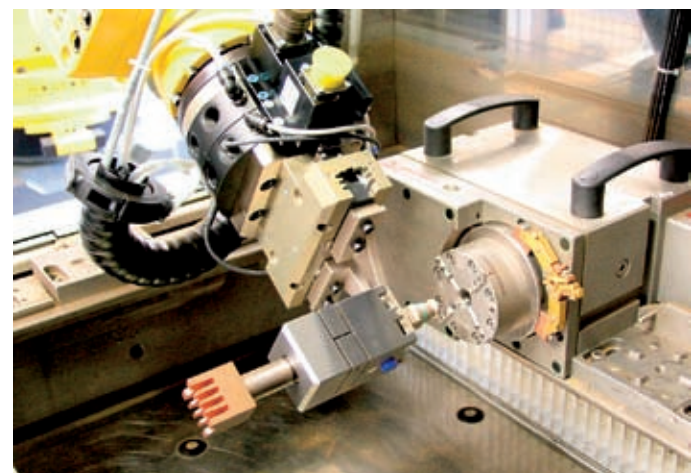

FIXTURING SYSTEM 4000
for Wire EDM

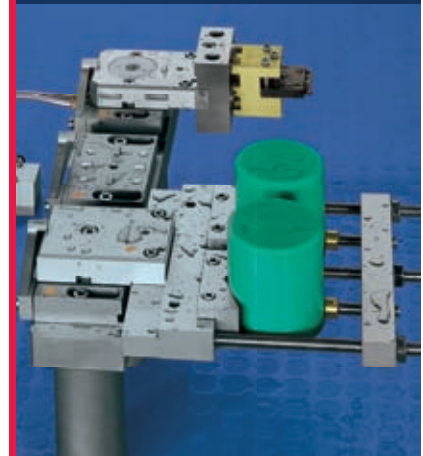

PRODUCT OVERVIEW

FIXTURING SYSTEM 5000
for Sinking EDM



PALLETIZING SYSTEM 8000
for Machine Tools



FIXTURING SYSTEM 9000
Modular Zero-Point Fixturing



**HEAVY-DUTY ROD ENDS and
SPHERICAL BEARINGS**



ROTARY TABLES, A-AXES, SPINDLES
for Wire and Sinking EDM

